



CUSTOMER NAME _____

Project Name _____

Date _____ Type _____

Catalog Number _____

DECAUX MAX Series

Remodel and New Construction

Decaux Max architectural LED downlights deliver ultimate performance, efficiency and design flexibility. A custom-engineered spec grade optical system featuring TriGain® provides exceptional color and clarity with 45° cutoff and no glare, perfect for quiet ceiling design. Tool-free installation from below the ceiling plane installs rapidly in minutes, with available matching frame kits for new construction applications.

CONSTRUCTION

Housing:	Galvanized steel junction box with multiple knockouts
Heatsink:	Custom engineered to provide superior passive cooling performance
Lens:	Polycarbonate diffused, acrylic clear
Optical Assembly:	Wet rated lenses include tempered glass designed not to break during moderate turbulence. Perfect for shower/bathroom applications (up to 4000lm)
Paint:	Powder coat painted reflector options
Weight:	4.5 lbs – 6.0 lbs
Application:	Interior covered

OPTICAL SYSTEM

Lumens:	1000–6000
Distribution	Narrow (36°), Wide (56°), Wall Wash
Efficacy:	100–116 LPW
Wattage:	10–63 watts
CCT:	2700K, 3000K, 3500K, 4000K, 5000K
CRI (Min):	83 CRI, TriGain® 90

ELECTRICAL

Input Voltage:	120–277V, 120V, 277V, & 347V
Input Frequency:	50/60Hz
Power Factor (PF):	>0.9*
Total Harmonic Distortion (THD):	<20%*
Thermal Protection:	Yes
Temperature/Humidity:	35°C Ambient, Damp
Surge Protection:	ANSI C82.77 Complaint
LED Driver Type:	Class 2, Lutron EcoSystem®

*At 120V. PF and THD may vary with Voltage and Lumen Output

CONTROLS

Standard Dimming:	0–10VDC [ANSI C137.x] compliant
Minimum Dimming:	Standard 0–10V dims down to 1%
Wireless Networking & Sensing:	ZigBee Wireless Daintree® with No Sensor Lutron HiLume EcoSystem 0.1% dimming

AMBIENT TEMPERATURE

TYPE	TEMPERATURE RATE
Operating Temperature:	–20°C to +30°C*
Storage Temperature:	–40°C to +70°C

LUMEN MAINTENANCE

50,000 HR	
LRC	Projected L85

MOUNTING

- **Typical Mounting:** Spring assembly with trigger quick release installation to frame. Junction box rests securely on most existing downlight frames. Hanger bars (BH3 - 93110306) for T-grid.
- **Ceiling:** Compatible with thickness up to 1.5".
- **Wiring Access:** ½" trade-size KOs on a removable access plate provided.

DESIGN LIFE & WARRANTY

- **Reliability Testing:** Components and systems evaluation at extreme conditions and monitored during production.
- Thermal protection feature enables prevention of overheating.
- All components are designed to exceed 85,000 hours of rated life.
- **Optional Emergency Battery:** Provides 90-minutes of emergency lighting. 120–277V and only compatible with 0–10V dimming driver.
- **Current's Limited 5-year Warranty:** Please see website.



CUSTOMER NAME

Project Name _____

Date _____ Type _____

Catalog Number _____

LRC C R

FAMILY	GENERATION	FIXTURE TYPE	VOLTAGE	LUMEN OUTPUT	DISTRIBUTION	REFLECTOR FINISH	REFLECTOR COLOR	FLANGE COLOR	CRI	CCT	DRIVER & CONTROLS	OPTIONS ¹²
LRC = Lumination® Retrofit Commercial Downlight	C = Next Generation	06R = 6" Round	0 ¹ = 120 – 277V	10 = 1000 lm	NR = Narrow (36°)	SD ³ = Semi-Diffused	CL = Clear (no color)	MR = Match Reflector	8 ⁵ = 83 CRI	27 ⁵ = 2700K	V1 ¹ = 0 –10V Dimming, 1%	(blank) = None
		08R = 8" Round	1 = 120V	15 = 1500 lm	WD = Wide (56°)				T ⁴ = TriGain® 90 CRI	30 = 3000K	TS ⁹ = Daintree Enterprise Wireless Enabled with Daintree WFA100	CP ¹³ = Chicago Plenum (CCEA) rated
		10R = 10" Round	4 ¹⁴ = 277V	20 = 2000 lm	WW ² = Wall Wash	PT ^{3,7} = (Painted white reflector color and white flange color only)	WT ⁷ = White Paint	WT ⁷ = White Paint		35 = 3500K	LQ ^{6,10} = Hi-Lume 1% EcoSystem 3 wire L3DA	EL ^{11,13} = Emergency Light
		12R ⁷ = 12" Round	D ^{8,13} = 347V	30 = 3000 lm 40 = 4000 lm 50 = 5000 lm 60 = 6000 lm						40 = 4000K 50 ⁵ = 5000K	LE ^{6,10} = Lutron LDE1 Hi-lume 0.1% Ecosystem w/ Soft-on, Fade-to-Black	WR ⁷ = Wet rated

Notes:

- 120–277V available for 1000lm–6000lm with V1 option
- Wall wash not available in 12" Reflector or painted reflector finish.
- All-white painted reflectors order PT reflector finish and WT flange color (i.e. PTWTWT). SD reflectors order CL reflector color and MR or WT flange color (i.e. SDCLMR or SDCLWT)
- TriGain® available up to 4000lm with 3000K, 3500K and 4000K CCT for V1 and TS options. For PQ, LQ and LE Options, TriGain® available up to 2000lm with 3500K and 4000K CCT
- 2700K and 5000K available only in 83 CRI.
- LE and LQ available only up to 4000 lumens and with 120V
- Wet rated available up to 4000lm. Available only with WD beam spread. WR option not available for PT Reflector Finish. WR not available with 12" reflector.
- LE, LQ, TS controls not available with 347V.
- Available up to 5000lm options and for 120-277V
- Type IC only available at 1000 and 1500 lumens with Lutron.
- EL not available with 347V and only compatible with 0–10V dimming. EL option adds 5W to system wattage.
- Check with manufacturer for other options not listed.
- CP option for Chicago Plenum (CCEA) is not compatible with 347V (D) or Emergency Light (EL) options. Available only with 0–10V Dimming (V1) option.
- Only available with LQ option.

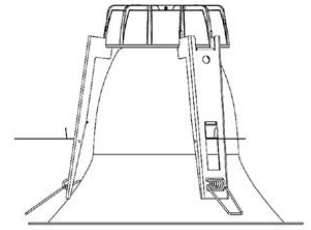
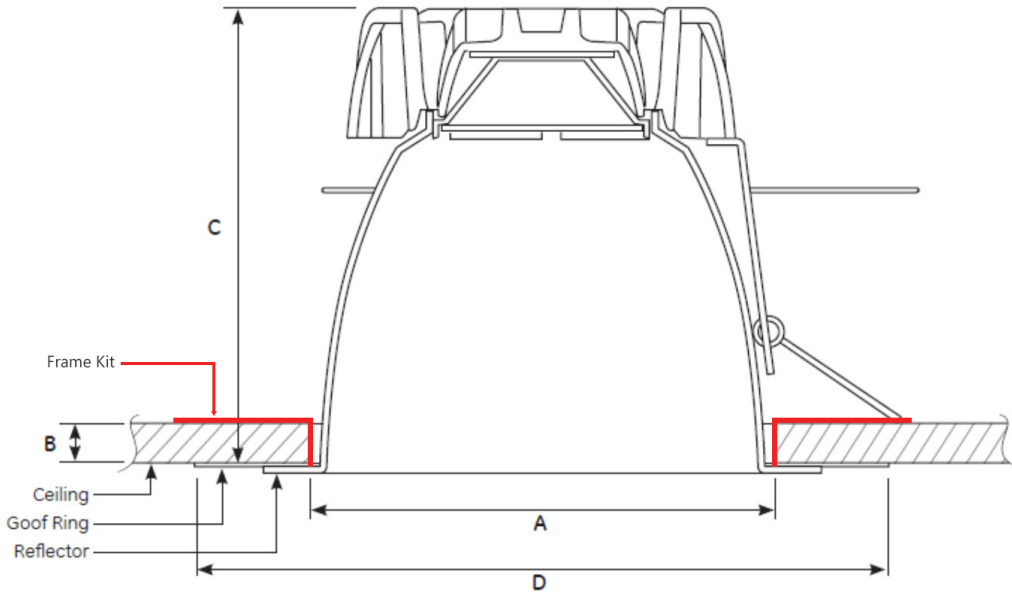

LRC 8", 10", 12"

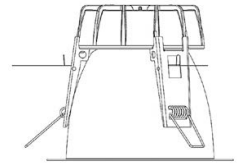

LRC 6"

Dimension	Item	RC6	RC8	LRC10	RC12
A	Applicable Hole Diameter (inches)	6.4 – 6.8	7.5 – 8.5	9.5 – 10	11.75 – 12.25
B	Applicable Ceiling Thickness (inches)	0.5 – 1.3	0.5 – 1.3	0.5 – 1.3	0.5 – 1.3
C	Height from Bottom of Ceiling (inches) (1000lm – 3000lm)	5.9	7.3	8.7	9.7
C	Height from Bottom of Ceiling (inches) (4000lm – 6000lm)	6.65	8.1	9.35	10.45
D	Outer Diameter of Goof Ring (inches)	8.5	10.2	12.1	N/A

MINIMUM SPACING REQUIREMENTS FOR ALL FIXTURE CONFIGURATIONS

Center to center of adjacent luminaires	24"
Top of Luminaire to overhead building member	3"
Luminaire center to side building member	12"

Reflector Orientation When Mounting LRCXXXXXXWXXXXXXXXXX SKUs

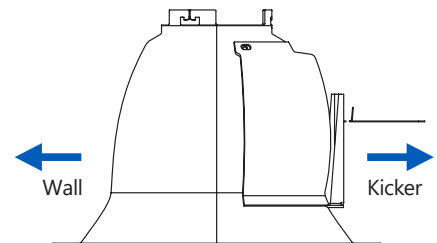

CUSTOMER NAME

Project Name _____

Date _____ Type _____

Catalog Number _____

STANDARD

NOMINAL LUMENS	1000	1500	2000	3000	4000	5000	6000
Fixture Lumens	1044	1543	2027	2964	4081	5021	6025
System Input Power (W)	9.6	14.0	18.5	27.9	38.8	49.6	65.6
System Efficacy (LPW)	109	110	110	106	105	101	92

STANDARD 83 CRI SCALING TABLE	
CCT	Scale
2700	0.91
3000	0.96
3500	0.97
4000	1.00
5000	1.02

Configuration Notes:

1. Table based on 4000K CCT using semi-diffused finish with 120V Input
2. For painted white reflector [PTWTWT], multiply lumen output by an additional .75 factor

TriGain[®]
 technology

NOMINAL LUMENS	1000	1500	2000	3000	4000
Fixture Lumens	1050	1558	2029	2883	3943
System Input Power (W)	9.6	14.0	18.5	27.8	38.6
System Efficacy (LPW)	109	111	110	104	102
CRI	90				
R9	>50				

TRIGAIN SCALING TABLE	
CCT	Scaling Factor
3000	0.95
3500	0.98
4000	1

Configuration Notes:

1. Table based on 3500K/4000K CCT using semi-diffused finish with 120V Input
2. For painted white reflector [PTWTWT] or wet rated reflector [WR], multiply lumen output by an additional .75 factor

CUSTOMER NAME

Project Name _____

Date _____ Type _____

Catalog Number _____

Accessories
 (ORDERED SEPARATELY)

**12" ROUND ADAPTER RING,
 SEMI-DIFFUSED, CLEAR: 93030117**

8" ROUND NEW CONSTRUCTION FRAME KIT: 93025092
10" ROUND NEW CONSTRUCTION FRAME KIT: 93124880
12" ROUND NEW CONSTRUCTION FRAME KIT: 93124881

PRODUCT DESCRIPTION	MATERIAL DESCRIPTION	MATERIAL
HANGER BAR, C-CHANNEL - 25 1/4" (Boxed Pair)	BH3	93110306
6" ROUND GOOF RING Semi-Diffused, Clear	GRR6RSDCL	93018828
6" ROUND GOOF RING, Painted, White	GRR6RPTWT	93018829
8" ROUND GOOF RING, Semi-Diffused, Clear	GRR8RSDCL	93018830
8" ROUND GOOF RING, Painted, White	GRR8RPTWT	93018831
10" ROUND GOOF RING, Semi-Diffused, Clear	GRR10RSDCL	93018833
10" ROUND GOOF RING, Painted, White	GRR10RPTWT	93018834
12" ROUND GOOF RING, Semi-Diffused, Clear	GRR12RSDCL	93066721
12" ROUND GOOF RING, Painted, White	GRR12RPTWT	93066722
12" ROUND ADAPTER RING, Semi-Diffused, Clear	A12RC10RSDPA	93030117
12" ROUND ADAPTER RING, Painted, White	A12RC10RPTWT	93030118
6" ROUND NEW CONSTRUCTION FRAME KIT*	FRAME6R	93025091
8" ROUND NEW CONSTRUCTION FRAME KIT	FRAME8R	93025092
10" ROUND NEW CONSTRUCTION FRAME KIT	FRAME10R	93124880
12" ROUND NEW CONSTRUCTION FRAME KIT	FRAME12R	93124881
DAINTREE CONTROLS KIT (does not include sensor)	LCAMBA0TQFM	93057194

NARROW BEAM

LRCXRBX30NRSDXXXX840XXX

COEFFICIENTS OF UTILIZATION

RC	80%				70%				50%				30%				10%				0%	
	RW	70%	50%	30%	10%	70%	50%	30%	10%	70%	50%	30%	10%	70%	50%	30%	10%	70%	50%	30%	10%	0%
0	119	119	119	119	116	116	116	116	111	111	111	111	106	106	106	106	102	102	102	102	100	
1	114	112	110	108	112	110	108	106	106	104	103	102	101	100	99	98	97	95	95	95	95	95
2	110	105	102	99	108	104	101	98	101	98	96	98	96	94	95	93	92	90	90	90	90	90
3	105	100	95	92	103	98	94	91	96	93	90	93	91	88	91	89	87	86	86	86	86	86
4	101	94	90	86	99	93	89	86	91	88	85	89	86	84	88	85	83	81	81	81	81	81
5	97	90	85	81	95	89	84	81	87	83	80	86	82	79	84	81	79	77	77	77	77	77
6	93	85	80	77	92	85	80	77	83	79	76	82	78	76	81	78	75	74	74	74	74	74
7	89	82	76	73	88	81	76	73	80	75	72	79	75	72	78	74	72	70	70	70	70	70
8	86	78	73	69	85	77	73	69	76	72	69	75	72	69	75	71	68	67	67	67	67	67
9	83	75	70	66	82	74	69	66	73	69	66	72	69	66	72	68	65	64	64	64	64	64
10	80	72	67	63	79	71	66	63	70	66	63	70	66	63	69	65	63	62	62	62	62	62

POLAR GRAPH

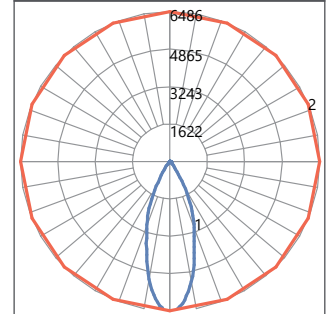

EFFECTIVE FLOOR CAVITY REFLECTANCE 0.20

ZONAL LUMEN SUMMARY			
ZONE	LUMENS	% OF LAMP	% OF FIXTURE
0-20°	1677.01	N/A	56.60
0-30°	2613.47		88.20
0-40°	2903.21		98.00
0-60°	2958.69		99.90
0-80°	2963.05		100.00
0-90°	2963.06		100.00

LUMINANCE DATA (CD/SQ.M)			
ANGLE IN DEGREES	0°	45°	90°
45°	3867	3640	3640
55°	1122	1122	1122
65°	380	380	380

ZONAL LUMEN SUMMARY	
ZONE	LUMENS
0-10	560.15
10-20	1116.86
20-30	936.46
30-40	289.74
40-50	43.41
50-60	12.07
60-70	4.02
70-80	0.34

Total Luminaire Efficiency = N.A.%

WIDE BEAM

LRCXRBX30WDSXXXX840XXX

COEFFICIENTS OF UTILIZATION

RC	80%				70%				50%				30%				10%				0%	
	RW	70%	50%	30%	10%	70%	50%	30%	10%	70%	50%	30%	10%	70%	50%	30%	10%	70%	50%	30%	10%	0%
0	119	119	119	119	116	116	116	116	111	111	111	111	106	106	106	106	102	102	102	102	100	
1	114	111	109	107	112	109	107	105	105	104	102	102	100	99	98	97	96	94	94	94	94	94
2	109	104	101	98	107	103	99	97	100	97	94	97	94	92	94	92	91	89	89	89	89	89
3	104	98	94	90	102	97	93	89	94	91	88	92	89	87	90	87	85	84	84	84	84	84
4	99	93	87	84	98	91	87	83	89	85	82	87	84	81	86	83	80	79	79	79	79	79
5	95	87	82	78	93	86	81	78	85	80	77	83	79	76	82	78	76	74	74	74	74	74
6	91	83	77	73	89	82	77	73	80	76	73	79	75	72	78	74	72	70	70	70	70	70
7	87	78	73	69	86	78	73	69	76	72	68	75	71	68	74	71	68	66	66	66	66	66
8	83	74	69	65	82	74	69	65	73	68	65	72	68	64	71	67	64	63	63	63	63	63
9	80	71	65	62	79	70	65	62	69	65	61	69	64	61	68	64	61	60	60	60	60	60
10	76	67	62	59	75	67	62	58	66	62	58	65	61	58	65	61	58	57	57	57	57	57

POLAR GRAPH

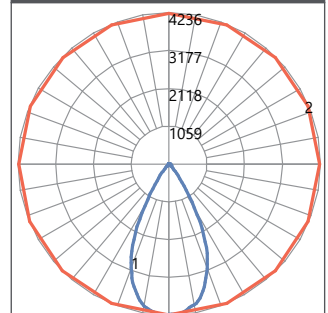

EFFECTIVE FLOOR CAVITY REFLECTANCE 0.20

ZONAL LUMEN SUMMARY			
ZONE	LUMENS	% OF LAMP	% OF FIXTURE
0-20°	1413.47	N/A	47.70
0-30°	2465.93		83.20
0-40°	2874.86		97.00
0-60°	2956.98		99.80
0-80°	2963.34		100.00
0-90°	2963.34		100.00

LUMINANCE DATA (CD/SQ.M)			
ANGLE IN DEGREES	0°	45°	90°
45°	6598	6143	5233
55°	1963	1682	1402
65°	761	761	761
75°	620	0	0

ZONAL LUMEN SUMMARY	
ZONE	LUMENS
0-10	394.29
10-20	1019.19
20-30	1052.45
30-40	408.93
40-50	65.88
50-60	16.25
60-70	5.21
70-80	1.15

Total Luminaire Efficiency = N.A.%

Note:

Photometric distributions in the LRC series are the same for 6", 8", 10", and 12"

CUSTOMER NAME

Project Name _____

Date _____ Type _____

Catalog Number _____

DAINTREE® CONTROLS

Daintree® Wireless Controls:

There is no one size fits all for wireless controls. Some networks want simple solutions that reduce energy consumption and meet code compliance while others are more ambitious, looking to capitalize on the LED and controls savings to fund a scalable, enterprise-grade, internet of things solution. The advantage of the Daintree® Wireless platform is it's ability to integrate into indoor, outdoor and high bay environments. The Daintree® Wireless Controls provide the infrastructure to future proof your buildings, easily upgrade to Networked solutions and provide the ability to integrate into IoT solutions that are right for your business.

- **Daintree® One:** Standalone Wireless Controls
- **Daintree® EZ Connect:** Room-Based Wireless Lighting Controls
- **Daintree® Networked:** Networked Lighting Controls for Smart Building & IoT Enablement

Daintree® Wireless Controls are already integrated in your favorite Current LED fixtures. Integrating the controls into the fixture cuts labor costs considerably since the sensors are already embedded in the lighting fixtures. There's no need to get above the ceiling plenum and install additional devices. Visit our website LED.com for a complete list of LED Fixtures that have Daintree® integrated controls.

**The Decaux Max series offers Daintree® Networked integral controls (Controls option TS).
Integral sensors and IoT devices are not offered at this time.**

LUTRON CONTROLS

Lutron EcoSystem: EcoSystem technology is a control method for LEDs that provides addressing of individual fixtures and status feedback from the LED drivers. This makes it easy to digitally assign occupancy sensors, daylight sensors, time clocks, manual controls and other controls to one or many fixtures without complicated wiring. This opens up an entire suite of energy-saving, system-monitoring and system-control schemes where the design, setup and rezoning are all done within software, making the electrical and control design simple.