



CUSTOMER NAME _____

Project Name _____

Date _____ Type _____

Catalog Number _____

DECAUX SMALL

2in Aperture Downlight

Decaux Small architectural downlights pack endless features into a true 2 inch aperture. Available in fixed and adjustable, the Decaux Series is versatile for nearly any downlight and wall wash application. Multiple bezel options, spec-grade finishes and an advanced optical design featuring Current's "Visual Comfort" lens brings your design to life without stealing the spotlight.

CONSTRUCTION

Housing:	All metal construction with aluminum trim
Lens:	Silicone
Paint:	Powder coat painted in white, black or silver
Weight:	5 lbs (2.7kg) total system
Optical Assembly:	High beam intensity, smooth beams with no color separation or pixelation

CONTROLS

Dimming:	Standard 0–10V, Lutron PEQ Hi-lume 0.1% EcoSystem®
Sensors:	Daintree® Compatible w/ Controls Kit (see Ordering for additional info)

CONTROLS

Lumens:	1000–2000lm
Distribution:	Spot (16°), Narrow Flood (20°), Flood (25°), Wide Flood (35°)
Efficacy:	Up to 109 LPW
CCT:	3000K, 3500K, 4000K
Adjustability Features:	360° rotations and 35° tilt
CRI (Min):	90 CRI

LUMEN AMBIENT TEMPERATURE

Product ID	OPERATING TEMPERATURE
LDXB2	-10° to +35° C

LUMEN MAINTENANCE

Projected Lxx per IES TM-21 at max 25°C
LXX(10K) @ Hours 50,000 HR
L85

ELECTRICAL

Input Voltage:	120–277V, 347V
Input Frequency:	50/60Hz
Standard Dimming Control:	0–10V, 1% Lutron hi-lume 0.1% Ecosystem
Power Factor (PF)*:	>0.9%
Total Harmonic Distortion (THD)*:	<20%

* System PF and THD specified at rated watts

MOUNTING

- Retrofit to existing frame
- New construction, utilizing FRAME2R or FRAME2S option (Includes adjustable hanger bars)

DESIGN LIFE & WARRANTY

- Damp Location rated



1. CATALOG LOGIC

LDXB2

0

9

FAMILY	FIXTURE TYPE	VOLTAGE	NOMINAL LUMEN	DISTRIBUTION	CRI	CCT	CONTROLS	FINISH	OPTIONS
LDXB2 = Lumination® Downlight, 2 inch Small Aperture	RA = Round Adjustable RF = Round Fixed SA = Square Adjustable SF = Square Fixed	0 = 120-77VAC	10 = 1000LM 15 = 1500LM 20 = 2000LM	SP = Spot (16°) NF = Narrow Flood (20°) FL = Flood (25°) WF = Wide Flood (35°)	9 = 90 CRI	30 = 3000K 35 = 3500K 40 = 4000K	V1 = 0-10V 1% LE = Lutron PEQ Hi-lume 0.1% EcoSystem®	WHITE = White SLVR = Silver BLCK = Black	(BLANK) = None XT* = Trimless <small>*XT option only available in Fixture Type "R"</small>

CCT	SCALING FACTOR	NOMINAL LUMEN	1000 LM	1500 LM	2000 LM
3000K	0.95	Fixture Deliverable Lumens	1029	1522	1915
3500K	1	System Input Power (W)	9.5	14.3	18.7
4000K	1.04	System Efficacy (LPW)	108.91	106.31	102.5

*Table based on 3500K CCT using white finish

2. PRODUCT DIMENSIONS

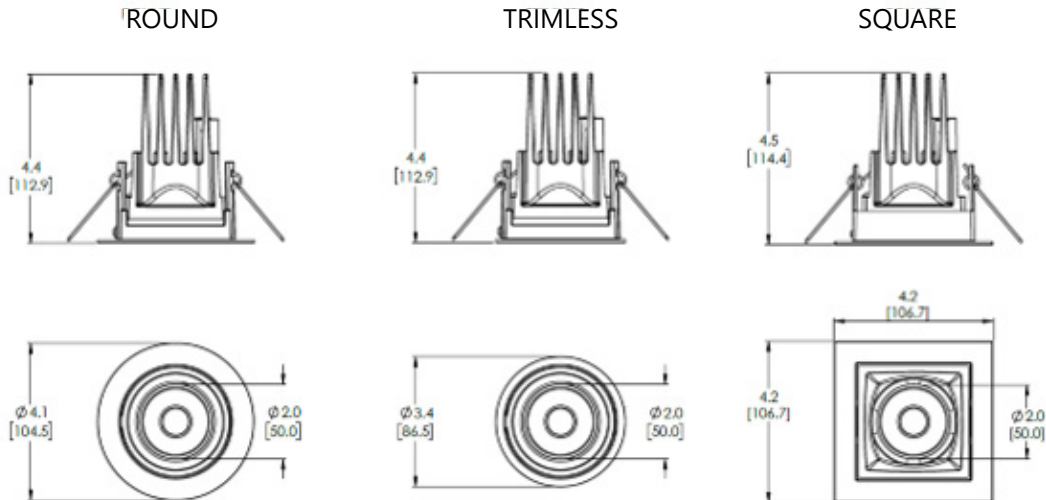

CONFIGURATION	HOLE SIZE (INCHES)	CEILING THICKNESS (INCHES)
ROUND	3.75-4.0	0.5-1.5
SQUARE	3.75 x 3.75-4.0 x 4.0	0.5-1.5
TRIMLESS	3.5	0.5-1.5

Refer to accessories page for more information on frame kits

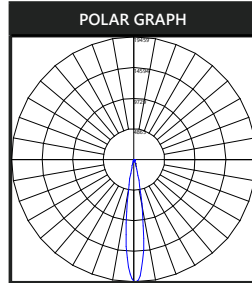
PHOTOMETRIC DATA
2" Spot Distribution
 LDXB2XX020SP935XX

ZONAL LUMEN SUMMARY	
Zone	Lumens
0-10	1115.47
10-20	538.74
20-30	96.37
30-40	67.20
40-50	41.99
50-60	28.58
60-70	15.59
70-80	5.89
80-90	1.23
90-100	0.00
100-110	0.00
110-120	0.00
120-130	0.00
130-140	0.00
140-150	0.14
150-160	1.11
160-170	1.89
170-180	0.80

ZONAL LUMEN SUMMARY		
Zone	Lumens	% of Fixture
0-20	1654.21	86.40
0-30	1750.58	91.40
0-40	1817.78	94.90
0-60	1888.35	98.60
0-80	1909.83	99.70
0-90	1911.06	99.80
10-90	795.59	41.50
20-40	163.57	8.50
20-50	205.56	10.70
40-70	86.16	4.50
60-80	21.48	1.10
70-80	5.89	0.30
80-90	1.23	0.10
90-110	0.00	0.00
90-120	0.00	0.00
90-130	0.00	0.00
90-150	0.14	0.00
90-180	3.94	0.20
Total Luminaire Efficiency	2.94	N.A.%
0-180	1915.00	100.00

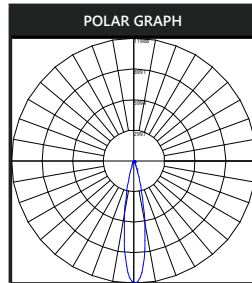
2" Narrow Flood Distribution
 LDXB2XX020NF935XX

ZONAL LUMEN SUMMARY	
Zone	Lumens
0-10	800.00
10-20	668.83
20-30	158.18
30-40	79.80
40-50	53.10
50-60	33.24
60-70	16.31
70-80	3.35
80-90	0.32
90-100	0.17
100-110	0.17
110-120	0.16
120-130	0.16
130-140	0.18
140-150	0.36
150-160	1.09
160-170	1.55
170-180	0.65

ZONAL LUMEN SUMMARY		
Zone	Lumens	% of Fixture
0-20	1468.83	80.80
0-30	1627.00	89.50
0-40	1706.8	93.90
0-60	1793.14	98.70
0-80	1812.79	99.70
0-90	1813.12	99.80
10-90	1013.12	55.70
20-40	237.98	13.10
20-50	291.07	16.00
40-70	102.65	5.60
60-80	19.65	1.10
70-80	3.35	0.20
80-90	0.32	0.00
90-110	0.34	0.00
90-120	0.50	0.00
90-130	0.66	0.00
90-150	1.20	0.10
90-180	4.49	0.20
110-180	4.15	0.20
0-180	1817.61	100.00

Total Luminaire Efficiency = N.A.%

PHOTOMETRIC DATA

2" Flood Distribution LDXB2XX020FL935XX

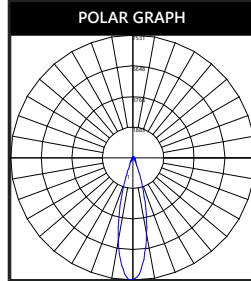

ZONAL LUMEN SUMMARY	
Zone	Lumens
0-10	584.96
10-20	785.16
20-30	272.35
30-40	122.54
40-50	72.97
50-60	44.56
60-70	21.52
70-80	5.77
80-90	1.03
90-100	0.00
100-110	0.00
110-120	0.00
120-130	0.00
130-140	0.02
140-150	0.42
150-160	1.26
160-170	1.68
170-180	0.74

ZONAL LUMEN SUMMARY		
Zone	Lumens	% of Fixture
0-20	1370.13	71.50
0-30	1642.48	85.80
0-40	1765.02	92.20
0-60	1882.56	98.30
0-80	1909.84	99.70
0-90	1910.88	99.80
10-90	1325.91	69.20
20-40	394.90	20.60
20-50	467.87	24.40
40-70	139.05	7.30
60-80	27.29	1.40
70-80	5.77	0.30
80-90	1.03	0.10
90-110	0.00	0.00
90-120	0.00	0.00
90-130	0.00	0.00
90-150	0.44	0.00
90-180	4.12	0.20
110-180	4.12	0.20
0-180	1915.00	100.00

Total Luminaire Efficiency = N.A.%

2" Wide Flood Distribution LDXB2XX020WF935XX

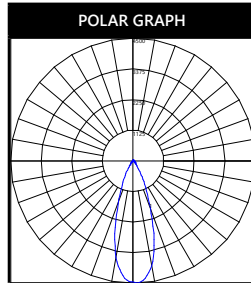

ZONAL LUMEN SUMMARY	
Zone	Lumens
0-10	392.69
10-20	731.32
20-30	452.24
30-40	180.78
40-50	80.36
50-60	46.05
60-70	21.23
70-80	5.49
80-90	0.95
90-100	0.00
100-110	0.00
110-120	0.00
120-130	0.00
130-140	0.15
140-150	0.55
150-160	1.24
160-170	1.38
170-180	0.60

ZONAL LUMEN SUMMARY		
Zone	Lumens	% of Fixture
0-20	1124.00	58.70
0-30	1576.24	82.30
0-40	1757.02	91.70
0-60	1883.43	98.40
0-80	1910.15	99.70
0-90	1911.1	99.80
10-90	1518.42	79.30
20-40	633.01	33.10
20-50	713.38	37.30
40-70	147.65	7.70
60-80	26.72	1.40
70-80	5.49	0.30
80-90	0.95	0.00
90-110	0.00	0.00
90-120	0.00	0.00
90-130	0.00	0.00
90-150	0.70	0.00
90-180	3.91	0.20
110-180	3.91	0.20
0-180	1915.02	100.00

Total Luminaire Efficiency = N.A.%

ACCESSORIES

PRODUCT DESCRIPTION	MATERIAL DESCRIPTION	MATERIAL	COMPATIBLE PRODUCTS
C-CHANNEL – 25 1/4", HANGER BAR (BOXED PAIR)	BH3	93110306	LDX, FRAME KITS
347V KIT	LRX347V277	93036250	347V TRANSFORMER QUICK CONNECT KIT

FRAME KIT

PRODUCT DESCRIPTION	MATERIAL DESCRIPTION	MATERIAL	NOTES
2" NEW CONSTRUCTION SQUARE FRAME KIT	LDXBSA-KIT-ROUGH-IN-PLATE-SQUARE	93142594	RECOMMENDED FOR NEW CONSTRUCTION APPLICATIONS; INCLUDES ADJUSTABLE HANGER BARS (BOXED PAIR)
2" NEW CONSTRUCTION ROUND FRAME KIT	LDXBSA-KIT-ROUGH-IN-PLATE-ROUND	93142595	RECOMMENDED FOR NEW CONSTRUCTION APPLICATIONS; INCLUDES ADJUSTABLE HANGER BARS (BOXED PAIR)

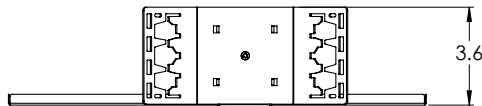
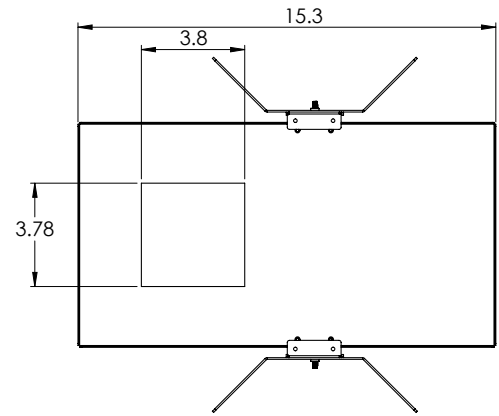
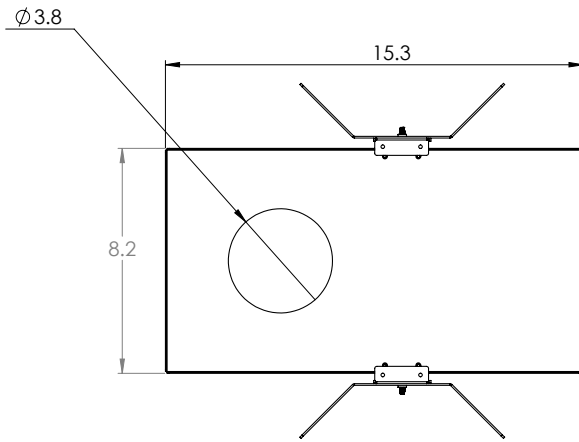

CONFIGURATION	HOLE SIZE (INCHES)	DIMENSIONS (INCHES)
ROUND	3.8	15.3 x 8.2 x 3.6
SQUARE	3.8 x 3.8	

DAINTREE CONTROLS

Daintree® Wireless Controls:

There is no one size fits all for wireless controls. Some networks want simple solutions that reduce energy consumption and meet code compliance while others are more ambitious, looking to capitalize on the LED and controls savings to fund a scalable, enterprise-grade, internet of things solution. The advantage of the Daintree® Wireless platform is it's ability to integrate into indoor, outdoor and high bay environments. The Daintree® Wireless Controls provide the infrastructure to future proof your buildings, easily upgrade to Networked solutions and provide the ability to integrate into IoT solutions that are right for your business.

- **Daintree® One:** Standalone Wireless Controls
- **Daintree® EZ Connect:** Room-Based Wireless Lighting Controls
- **Daintree® Networked:** Networked Lighting Controls for Smart Building & IoT Enablement

Daintree® Wireless Controls are already integrated in your favorite Current LED fixtures. Integrating the controls into the fixture cuts labor costs considerably since the sensors are already embedded in the lighting fixtures. There's no need to get above the ceiling plenum and install additional devices. Visit our website LED.com for a complete list of LED Fixtures.

The LDX Series Architectural Luminaire will offer Daintree® Networked integral controls (Controls options TQ & TS). Integral sensors and IoT devices are not offered at this time.

LUTRON PEQ HI-LUME 0.1% ECOSYSTEM®

0.1% Dimming for virtually any LED fixture

Compatibility

- Available in two form factors
- Supports a wide range of current and voltage levels (up to 53 watts)

Unmatched performance

- Dims continuously from a 100% to 0.1% lighting level
- Precision microprocessor control and integral thermal management