

LUEL Series

LED | Edge-Lit
Exit Sign



CUSTOMER NAME _____

Project Name _____

Date _____ Type _____

Catalog Number _____

- Recessed or Surface Mount
- AC only or Emergency Models
- Superior panel illumination with Red or Green letters
- LED life-cycle of more than 10 years
- Damp Location Listed 20°C to 30°C (68°F to 86°F)
- Dual-voltage 120 or 277V AC input
- Low Input Power Consumption at 3.72 Watts
- Field installed directional arrow indicators with template
- Mirror divider on single and double-face models

SPECIFICATIONS

APPLICATION

- The LUEL Series is applied in stairwells, hallways, offices and other commercial applications
- The housing finish and trim-plate is brushed aluminum
- Recessed mount model comes with a full recessed box complete with integrated caddy-bar assembly
- Surface mount model has a clam-shell design for easy installation and access to internal circuitry

CONSTRUCTION

- The acrylic panels are ultrasonically welded and taped at the edges to maximize illumination and visibility

INSTALLATION

- The LUEL is ideal for architectural applications and offers surface and recessed mounting options
- The Exit panel can be ratcheted to various angles for mounting to angled surfaces
- Canopy and mounting hardware included

ELECTRICAL

- LED based emergency exit
- Emergency models include NiCad battery, status LED and Push-to-test switch

CERTIFICATIONS

- UL924 Listed for Damp Location
- NFPA 101 and NFPA 70
- OSHA
- CEC T20 Compliant

WARRANTY

- 2 year full unit warranty
- See Lumination Standard Warranty for additional information

ORDERING GUIDE

Catalog Number	Description
LUELS1RN	Surface Edgelit Exit Sign, Single Face, Red Letters, Mirror Panel, Aluminum Housing, AC Only
LUELS1RNE	Surface Edgelit Exit Sign, Single Face, Red Letters, Clear Panel, Aluminum Housing, Battery Backup
LUELS1GN	Surface Edgelit Exit Sign, Single Face, Green Letters, Mirror Panel, Aluminum Housing, AC Only
LUELS1GNE	Surface Edgelit Exit Sign, Single Face, Green Letters, Clear Panel, Aluminum Housing, Battery Backup
LUELS2RN	Surface Edgelit Exit Sign, Double Face, Red Letters, Mirror Panel, Aluminum Housing, AC Only
LUELS2RNE	Surface Edgelit Exit Sign, Double Face, Red Letters, Mirror Panel, Aluminum Housing, Battery Backup
LUELS2GN	Surface Edgelit Exit Sign, Double Face, Green Letters, Mirror Panel, Aluminum Housing, AC Only
LUELS2GNE	Surface Edgelit Exit Sign, Double Face, Green Letters, Mirror Panel, Aluminum Housing, Battery Backup
LUELR1RN	Recessed Edgelit Exit Sign, Single Face, Red Letters, Mirror Panel, Aluminum Housing, AC Only
LUELR1RNE	Recessed Edgelit Exit Sign, Single Face, Red Letters, Mirror Panel, Aluminum Housing, Battery Backup
LUELR1GN	Recessed Edgelit Exit Sign, Single Face, Green Letters, Mirror Panel, Aluminum Housing, AC Only
LUELR1GNE	Recessed Edgelit Exit Sign, Single Face, Green Letters, Mirror Panel, Aluminum Housing, Battery Backup
LUELR2RN	Recessed Edgelit Exit Sign, Double Face, Red Letters, Mirror Panel, Aluminum Housing, AC Only
LUELR2RNE	Recessed Edgelit Exit Sign, Double Face, Red Letters, Mirror Panel, Aluminum Housing, Battery Backup
LUELR2GN	Recessed Edgelit Exit Sign, Double Face, Green Letters, Mirror Panel, Aluminum Housing, AC Only
LUELR2GNE	Recessed Edgelit Exit Sign, Double Face, Green Letters, Mirror Panel, Aluminum Housing, Battery Backup



LUEL Series

LED | Edge-Lit
Exit Sign

CUSTOMER NAME _____

Project Name _____

Date _____ Type _____

Catalog Number _____

DIMENSIONS

Surface LUEL

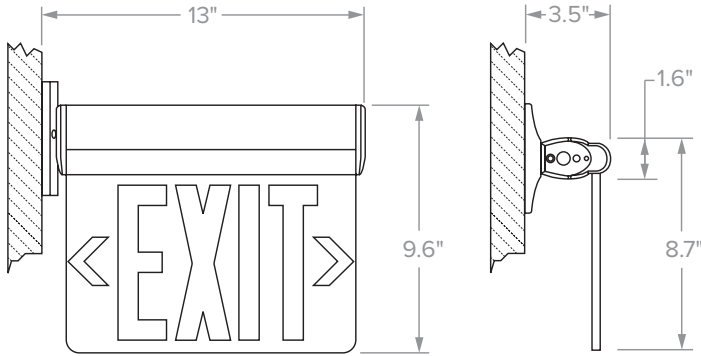

Recessed LUEL

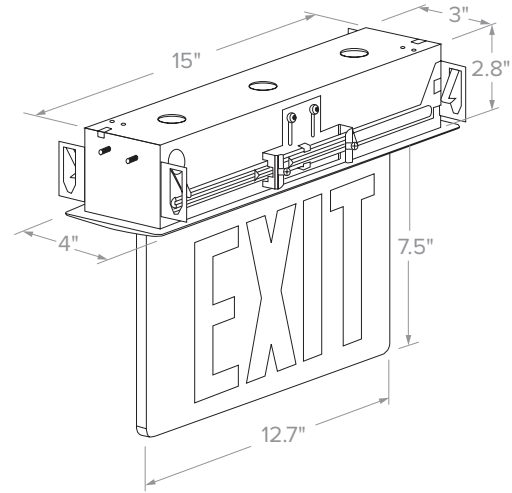

LUELS-Surface

Single Carton Weight	3.00lbs.
Master Carton Quantity	6 each

LUELR-Recessed

Single Carton Weight	6.00lbs.
Master Carton Quantity	3 each

ENERGY CONSUMPTION

	Input Power
LUELS1RN	2.38W
LUELS2RN	
LUELR1RN	
LUELR2RN	
LUELS1RNE	3.14W
LUELS2RNE	
LUELR1RNE	
LUELR2RNE	
LUELS1GN	2.39W
LUELS2GN	
LUELR1GN	
LUELR2GN	
LUELS1GNE	2.94W
LUELS2GNE	
LUELR1GNE	
LUELR2GNE	