

EPTC Twin Support Contemporary

LED Post Top Light



Project Name _____
 Date _____ Type _____
 Notes _____

The **Evolve**® LED Post Top Twin Support Contemporary (EPTC) offers energy efficiency and quality of light in your choice of two distinct, modern styles.

Construction

Housing:	Contemporary housing design. Die cast aluminum base with a spun aluminum top.
Lens:	UV resistant acrylic
Paint:	Corrosion resistant polyester powder paint, minimum 2.0 mil thickness Standard = Black, Dark Bronze RAL & custom colors available
Weight:	29.8 lbs. (13.5 kgs.) – 30.8 lbs. (14.0 kgs.)

Optical System

Lumens:	2,900 - 9,500
Distribution:	Symmetric Type V Asymmetric Type III
Efficacy:	103 - 118 LPW
CCT:	3000K, 4000K
CRI (Min):	≥70

Electrical

Input Voltage:	120-277V and 347-480V
Input Frequency:	50/60Hz
Power Factor:	≥ 90% at rated watts
Total Harmonic Distortion:	≤ 20% at rated watts

Surge Protection*

STANDARD	OPTIONAL
6kV/3kA	10kV/5kA

*Per ANSI C136.2-2015

Lumen Maintenance

Projected Lxx per IES TM-21 at 25°C

Lumen Codes	Distribution	LXX(10K) @ Hours		
		25,000 HR	50,000 HR	60,000 HR
03 - 09	A, B	L97	L96	L95

Note: Projected Lxx based on LM80 (≥ 10,000 hour testing). Accepted Industry tolerances apply to initial luminous flux and lumen maintenance measurements.

Luminaire Ambient Temperature Factor

Ambient Temp (°C)	Initial Flux Factor	Ambient Temp (°C)	Initial Flux Factor
10	1.02	30	0.99
20	1.01	40	0.98
25	1.00	50	0.97

Ratings

Operating Temperature:	-40°C to 50°C
Vibration:	2G per Per ANSI C136.31-2010
LM-79:	Testing in accordance with IES Standards

Controls

Dimming:	Standard - 0-10V Optional - DALI (Option U)
Sensors:	Photo Electric Sensors (PE) available LightGrid Compatible

Warranty

5 Year (Standard) 10 Year (Optional)



Not all product variations listed on this page are DLC qualified. Visit www.designlights.org/search to confirm qualifications.

Ordering Information

EPTC 02

PROD. ID	GEN	VOLTAGE	LUMENS	DISTRIBUTION	CCT	CONTROLS PER ANSI C136.41	TOP TYPE	COLOR	OPTIONS
E = Evolve	02	0 = 120-277V	03 = 3000 lm	A = Symmetric Type V	30 = 3000K	1 = None ³	A = Tiered Circular	BLCK = Black	R = Secondary 10kV/5kA SPD
P = Post Top		H = 347-480V ¹	04 = 4000 lm	B = Asymmetric Type III	40 = 4000K	A = 7-Pin PE Receptacle	B = Tiered Cone	DKBZ = Dark Bronze	U = DALI Programmable ²
TC= Twin Support Contemporary			05 = 5000 lm			D = 7-Pin PE Receptacle w/ Shorting Cap			XXX = Special Options
			06 = 6000 lm			E = 7-Pin PE Receptacle w/ non Dimming PE			
			07 = 7000 lm						
			08 = 8000 lm						
			09 = 9000 lm						

¹ Not available for 03 thru 06 lumen codes

² Not available for 347-480V

³ Not available with DALI

OPTICAL CODE	DIST CODE	TYPICAL INITIAL LUMEN OUTPUT		TYPICAL SYSTEM WATTAGE		BUG RATINGS		
		4000K	3000K	120-277V	347-480V	4000K	3000K	
03	Symmetric Type V	3100	2900	27	N/A	B2-U0-G1	B2-U0-G1	
04		4100	3800	35	N/A	B2-U0-G1	B2-U0-G1	
05		5100	4800	43	N/A	B3-U0-G1	B3-U0-G1	
06		6400	6000	54	N/A	B3-U0-G1	B3-U0-G1	
07		7300	6900	65		B3-U0-G1	B3-U0-G1	
08		8400	7900	74		B3-U0-G2	B3-U0-G2	
09		9500	8800	85		B3-U0-G2	B3-U0-G2	
03		Asymmetric Type III	3100	2900	27	N/A	B1-U0-G1	B0-U0-G1
04			4100	3800	35	N/A	B1-U0-G2	B1-U0-G1
05	5100		4800	43	N/A	B1-U0-G2	B1-U0-G2	
06	6400		6000	54		B1-U0-G2	B1-U0-G2	
07	7300		6900	65		B1-U0-G2	B1-U0-G2	
08	8400		7900	74		B1-U0-G2	B1-U0-G2	
09	9500		8800	85		B1-U0-G2	B1-U0-G2	

For additional information on EPTC IES files, please refer to LED.com



Not all product variations listed on this page are DLC qualified. Visit www.designlights.org/search to confirm qualifications.

EPTC02
Symmetric (Type V)

9,500 Lumens
4000K
EPTC02_09A40_.IES

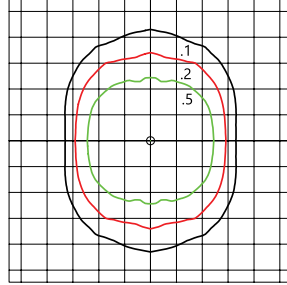

- Grid Distance in Units of Mounting Height at 16'
- Initial Footcandle Values at Grade

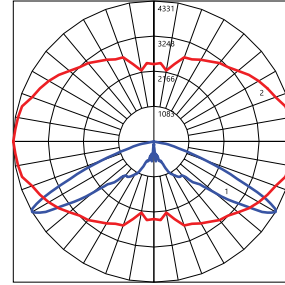

- Vertical plane through horizontal angle of Max. Cd at 0°
- Horizontal cone through vertical angle of Max. Cd at 60°

EPST02
Asymmetric (Type III)

9,500 Lumens
4000K
EPTC02_09B40_.IES

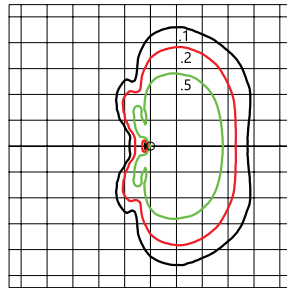

- Grid Distance in Units of Mounting Height at 16'
- Initial Footcandle Values at Grade

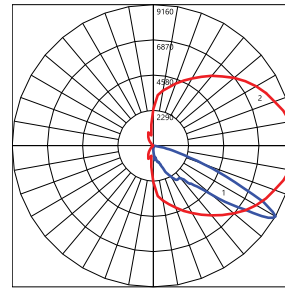

- Vertical plane through horizontal angle of Max. Cd at 0°
- Horizontal cone through vertical angle of Max. Cd at 60°

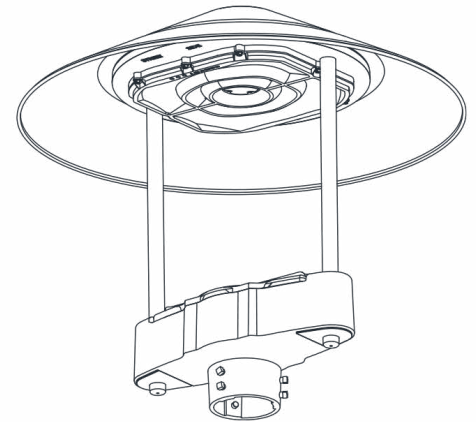
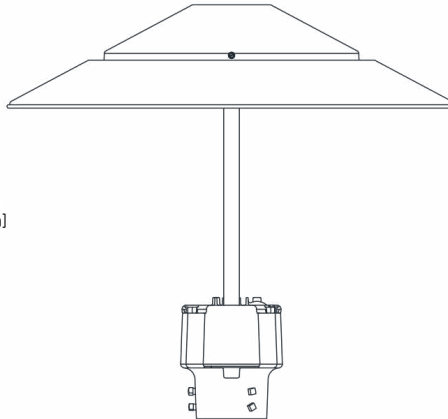
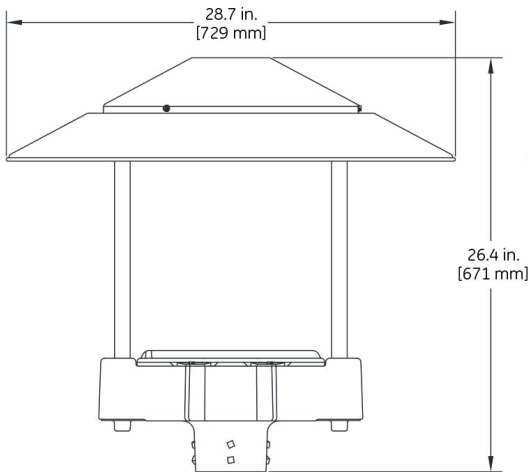
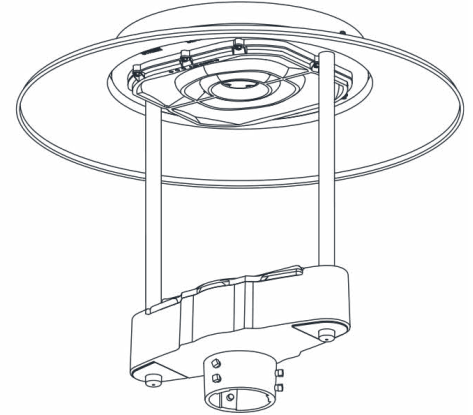
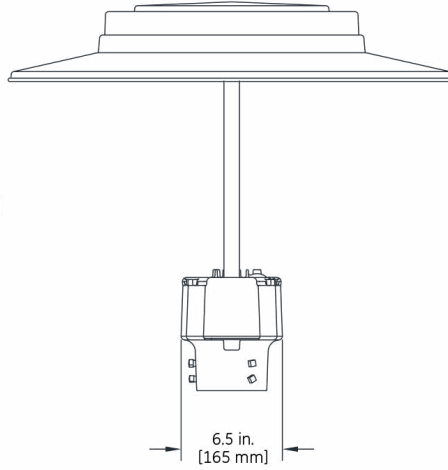
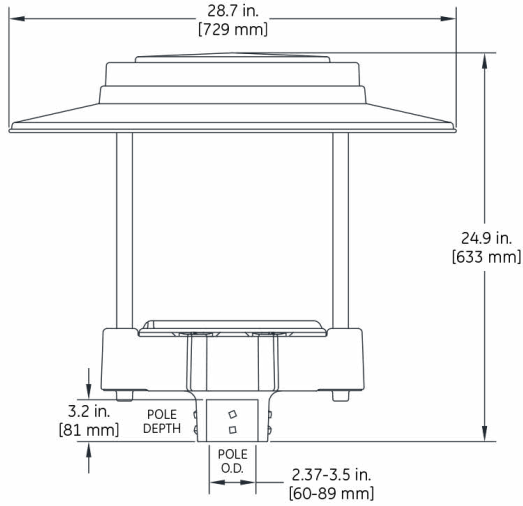

Mounting

- Mounts to 2-3/8 to 3-inch (60-76mm) OD vertical tenon
- Suggested Mounting Height = 8-16 ft. (2.5-5 m)

Weight

- 29.8 lbs (13.5 kgs) – 30.8 lbs (14.0 kgs)

Effective Projected Area

- 1.12 sq. ft. max (0.10 sq. m)