



CUSTOMER NAME _____
 PROJECT NAME _____
 DATE _____ TYPE _____
 CATALOG NUMBER _____

EPST Salem LED Post Top Light

The **Evolve**® LED Salem Post Top offers energy efficiency and quality of light in a classic, utility carriage look and style. The advanced LED optical system provides improved horizontal and vertical uniformity, reduced glare and improved lighting control. Current's unique optical ring technology effectively aims the light where you need it, while eliminating the unsightly shadow circles commonly seen under other LED post top fixtures.

Construction

Housing:	– Diecast aluminum housing. – Internal heat sink ensuring maximum heat transfer for long LED life.
Lens:	UV resistant polymer lens
Paint:	Corrosion resistant polyester powder paint, minimum 2.0 mils thickness. – Standard colors: Black, Dark Bronze – RAL & custom colors available

Optical System

Lumens:	2,800 – 8,900
Distribution:	Symmetric Type V Asymmetric Type III
Efficacy:	99 - 114 LPW
CCT:	3000K & 4000K
CRI (Min):	≥70

Electrical

Input Voltage:	120-277V and 347-480V
Input Frequency:	50/60Hz
Power Factor:	≥ 90% at rated watts
Total Harmonic Distortion:	≤ 20% at rated watts

Surge Protection*

Standard	Optional
6kV/3kA	Secondary 10kV/5kA (R Option)

*Per ANSI C136.2-2015

Warranty

5 Year (Standard)

10 Year (Optional)

Lumen Maintenance

Projected Lxx per IES TM-21 at 25°C

SKU	LXX(10K) @ Hours		
	25,000 HR	50,000 HR	60,000 HR
EPST	L97	L96	L94

Note: Projected LXX based on LM80 (> 10,000 hour testing). Accepted Industry tolerances apply to initial luminous flux and lumen maintenance measurements.

Luminaire Ambient Temperature Factor

Ambient Temp (°C)	Initial Flux Factor	Ambient Temp (°C)	Initial Flux Factor
10	1.02	30	0.99
20	1.01	40	0.98
25	1.00	50	0.97

Ratings

Operating Temperature:	-40°C to 50°C
Vibration:	2.0G (1.5G for Pendant Mount) per ANSI C136.31-2010
LM-79:	Testing in accordance with IES Standards
Environmental:	Complies with the material restrictions of RoHS
Sound:	Class "A" rating
Intrusion Protection (IP):	IP65 rated optical enclosure per ANSI C136.25-2009.

Controls

Dimming:	Standard - 0-10V Optional - DALI (Option U)
Sensors#:	Photo Electric Sensors (PE) available Lightgrid Compatible

Not available with Pendant Mount

Applications

- Local Roadways
- Parks and Pathways
- Antique Streetscapes
- University and Business Campuses

Not all product variations listed on this page are DLC qualified. Visit www.designlights.org/search to confirm qualifications.



CUSTOMER NAME _____
 PROJECT NAME _____
 DATE _____ TYPE _____
 CATALOG NUMBER _____

Ordering Information

EPST 02

PROD. ID	GEN	VOLTAGE	LUMENS	DISTRIBUTION	CCT	CONTROLS PER ANSI C136.41	TOP TYPE	COLOR	OPTIONS
E = Evolve	02	0 = 120-277V	03	A = Symmetric Type V	30 = 3000K ¹	1 = None	A = Salem	BLCK = Black	R = Enhanced Surge Protection (10kV/5kA)
P = Post Top		H = 347-480V ³	04	B = Asymmetric Type III	40 = 4000K	A = 7-Pin PE Receptacle	T = Pendant Mount ^{2, 5}	DKBZ = Dark Bronze	U = DALI Programmable ⁴
S = Salem			05			D = 7-Pin PE Receptacle w/ Shorting Cap			XXX = Special Options
T = Traditional			06			E = 7-Pin PE Receptacle w/ non Dimming PE			
			07						
			08						
			09						

¹ Select 3000K CCT for IDA approved units
² Please contact factory for availability
³ Not available for 03 thru 06 lumen codes
⁴ Not available with 347-480V
⁵ Need to use CONTROLS digit "1" when specifying the TOP TYPE "T" pendant mount

OPTICAL CODE	DIST. CODE	LUMEN OUTPUT		WATTAGE		BUG RATINGS		
		4000K	3000K	120-277V	347-480V	4000K	3000K	
03	Symmetric Type V	3000	2800	27	N/A	B2-U2-G1	B2-U1-G1	
04		4000	3800	35	N/A	B2-U2-G1	B2-U2-G1	
05		4900	4600	43	N/A	B3-U2-G1	B3-U2-G1	
06		6100	5700	54	N/A	B3-U2-G1	B3-U2-G1	
07		7000	6600	65		B3-U2-G1	B3-U2-G1	
08		7900	7500	74		B3-U2-G2	B3-U2-G1	
09		8900	8400	85		B3-U2-G2	B3-U2-G2	
03		Asymmetric Type III	3000	2800	27	N/A	B1-U2-G1	B1-U1-G1
04			4000	3800	35	N/A	B1-U2-G1	B1-U2-G1
05	4900		4600	43	N/A	B1-U2-G2	B1-U2-G1	
06	6100		5700	54	N/A	B1-U2-G2	B1-U2-G2	
07	7000		6600	65		B1-U2-G2	B1-U2-G2	
08	7900		7500	74		B2-U2-G2	B2-U2-G2	
09	8900		8400	85		B2-U2-G2	B2-U2-G2	

For additional information on EPST IES files, please refer to LED.com



Not all product variations listed on this page are DLC qualified. Visit www.designlights.org/search to confirm qualifications.

EPST02
SYMMETRIC TYPE V

8,900 Lumens
4000K
EPST02_05C540__IES

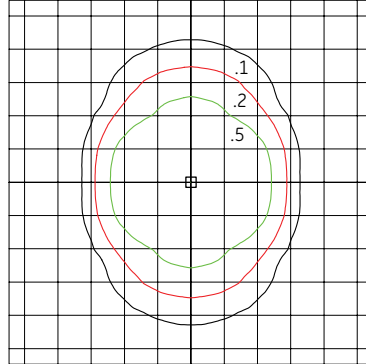

Grid Distance in Units of Mounting Height at 16'
Initial Footcandle Values at Grade

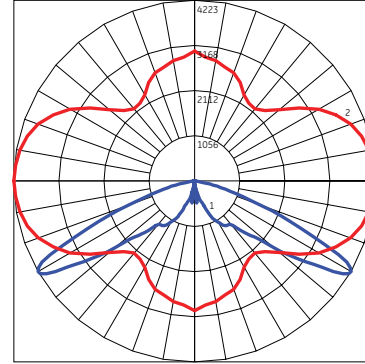

— Vertical plane through horizontal angle of Max. Cd at 0°
— Horizontal cone through vertical angle of Max. Cd at 60°

EPST02
ASYMMETRIC TYPE III

8,900 Lumens
4000K
EPST02_05V440__IES

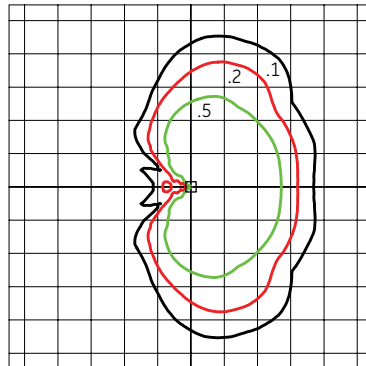

Grid Distance in Units of Mounting Height at 16'
Initial Footcandle Values at Grade

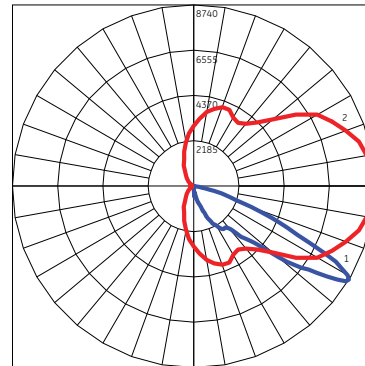

— Vertical plane through horizontal angle of Max. Cd at 0°
— Horizontal cone through vertical angle of Max. Cd at 59°

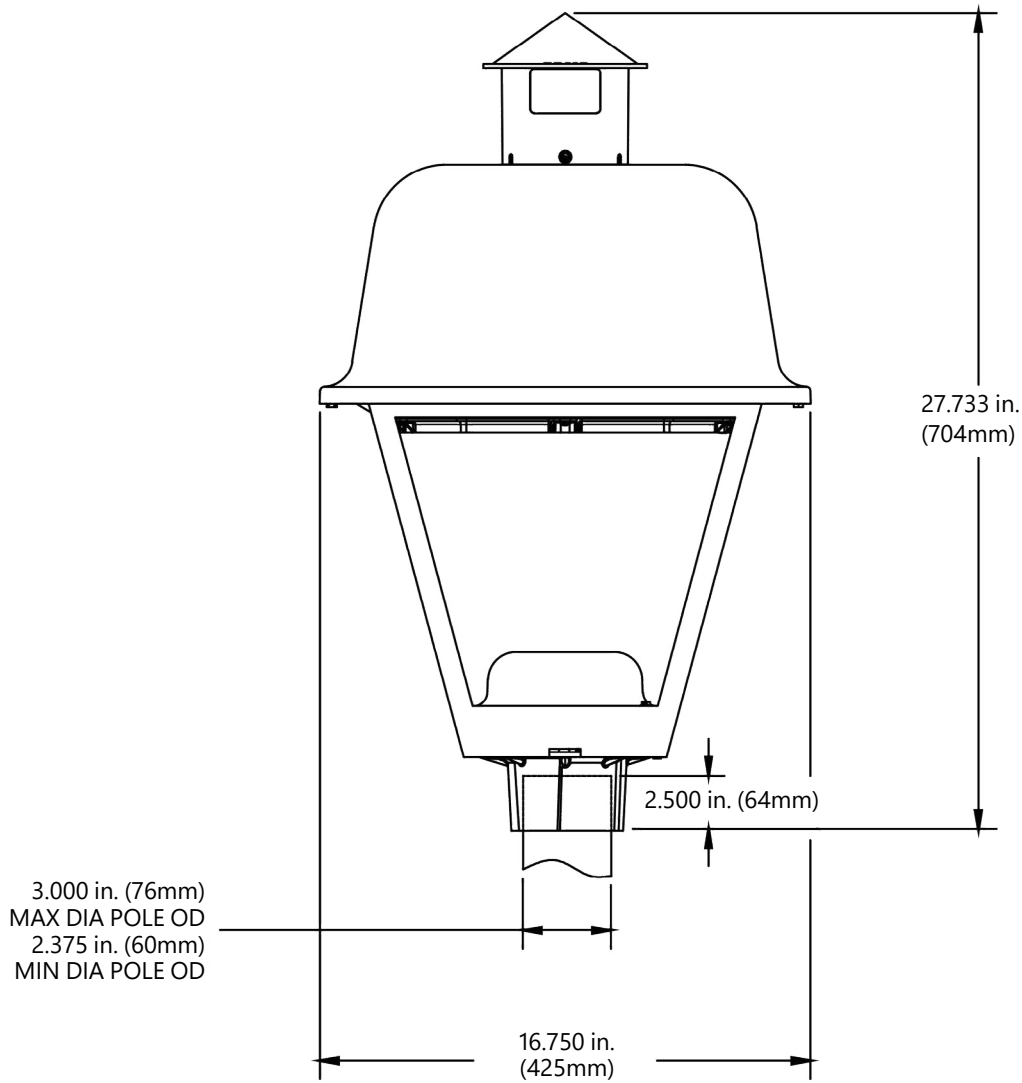

Weight

- 23 lbs (10.4 kgs) - 24 lbs (10.9 kgs)

Effective Projected Area

- 1.6 sq ft max (0.15 sq m)

Suggested Mounting Height

- 8-16 ft. (2.5-5 m)

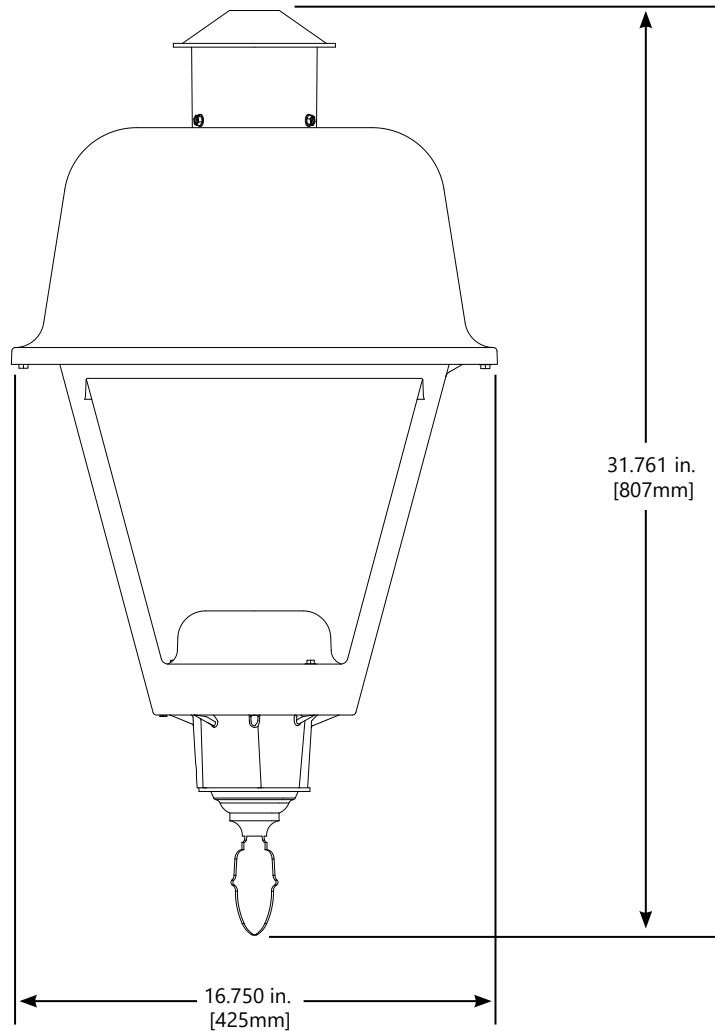

Weight

- 25 lbs (11.3 kgs) - 28 lbs (12.7 kgs)

Effective Projected Area

- 1.6 sq ft max (0.15 sq m)

Suggested Mounting Height

- 8-16 ft. (2.5-5 m)

Specific Pendant Mounting Information

