



ERL1 Cobra Head LED Roadway Lighting

The Evolve® LED Roadway ERL1 Luminaire is optimized utilizing advanced LED reflective optical system for local, collector and major roadways. The modern design incorporates the heat sink directly into the unit for heat transfer to prolong LED life.



Construction

Housing:	Aluminum die cast enclosure casting integral heat sink for maximum heat transfer
Lens:	Impact resistant tempered glass
Paint:	Corrosion resistant powder paint, ≥ 2.0 mil thickness (RAL & custom colors available) Standard = Black, Dark Bronze, Gray, White Optional = Coastal Finish
Weight:	12.4 lbs (5.6 kgs)

Optical System

Lumens:	2,000 - 15,700
Distribution:	Type II ,III, IV, Type II Narrow and Type II Enhanced Backlight
Efficacy:	111-140 LPW
CCT:	2700K, 3000K, 4000K and 5000K
CRI:	≥70

Electrical

Input Voltage:	120-277V or 347-480V
Input Frequency:	50/60Hz
Power Factor:	≥ 90% at rated watts
Total Harmonic Distortion:	≤ 20% at rated watts

Surge Protection*

STANDARD	OPTIONAL
10kV/5kA	Secondary 10kV/5kA (R Option) or Secondary 20kV/10kA (T Option)

*Per ANSI C136.2-2018

Lumen Maintenance

Projected Lxx per IES TM-21-11 at 25°C

LUMEN CODES	DISTRIBUTIONS	LXX(10K) @ HOURS		
		25,000 HR	50,000 HR	60,000 HR
02,03,04,05,06	A5, B5, C5, D5, E5	L96	L94	L93
07,08	A5, B5, C5, D5, E5	L99	L98	L98
09	A5, B5, C5, D5, E5	L98	L97	L96
10	A5, B5, C5, D5, E5	L94	L87	L84
11	A5, B5, C5, D5, E5	L93	L85	L82
12	A5, B5, C5, D5, E5	L96	L95	L94
13	A5, B5, C5, D5, E5	L96	L94	L93
14	A5, B5, C5, D5, E5	L95	L92	L91
15	A5, B5, C5, D5, E5	L93	L88	L86
16	A5, B5, C5, D5, E5	L91	L85	L83

Note: Projected Lxx based on LM80 (≥ 10,000 hour testing). Accepted Industry tolerances apply to initial luminous flux and lumen maintenance measurements.

Ratings

Operating Temp:	-40°C to 50°C
Vibration:	3G per ANSI C136.31-2018
LM-79:	Testing in accordance with IES Standards
EMI:	Title 47 CFR Part 15 Class A
RoHS:	Complies with the material restrictions of RoHS

Controls

Dimming:	Standard-0-10V Optional-DALI (Option U)
Sensors:	Photo Electric Sensors (PE) available LightGrid+™ Compatible

Warranty

5 Year (Standard)

10 Year (Optional)



Ordering Information

ERL1

PROD. ID	VOLTAGE	LUMENS	DISTRIBUTION ³	CCT	CONTROLS PER ANSI C136.41	COLOR	OPTIONS
E = Evolve	0 = 120-277V ^{1,2}	02 = 2000 lm ²	A5 = Type II Narrow	27 = 2700K ⁴	A = 7-Pin Receptacle	GRAY = Gray	A = 4 Bolt Slipfitter ⁵
R = Roadway	H = 347-480V ¹	03 = 3000 lm	B5 = Type II	30 = 3000K ⁴	D = 7-Pin Receptacle with Shorting Cap	BLCK = Black	B = Tether
L = Local	1 = 120V	04 = 4000 lm	C5 = Type III	40 = 4000K	E = 7-Pin Receptacle with non-dimming Long Life PE	DKBZ = Dark Bronze	F = Fusing
1 = Single Module	2 = 208V	05 = 5000 lm	D5 = Type IV	50 = 5000K	Note: 0-10V standard	WHTE = White	G = Internal Bubble Level
	3 = 240V	06 = 6000 lm	E5 = Type II Enhanced Back Light				I = Optional IP66 Optical Enclosure
	4 = 277V	07 = 7000 lm					L = Tool-Less Entry
	8 = 120-240V ¹¹	08 = 8000 lm					R = Enhanced Surge Protection (10kV/5kA)
	5 = 480V	09 = 9000 lm					T = Secondary 20kV/10kA SPD
	D = 347V	10 = 10000 lm					U = DALI Programmable ^{6,7}
		11 = 11000 lm					V1 = Field Adjustable Module ^{10, 12}
		12 = 12000 lm					X = Single Pack ⁸
	13 = 13000 lm		Y = Coastal Finish ⁹				
	14 = 14000 lm		XXX = Special Options				
	15 = 15000 lm						
	16 = 16000 lm						

¹ Fusing requires discrete voltage.

² 02 Lumen Level, Voltage options 1, 2, 3 and 8 only

³ Nominal IES Type and classing subject to typical variation, individual units may differ

⁴ Select 2700K or 3000K CCT for IDA approved units

⁵ Lead time varies, contact Factory

⁶ Compatible with LightGrid+™

⁷ Not available in 347V, 480V or 347-480V for Lumen Output Levels 08-16

⁸ Option provides single pack box per fixture. Standard packaging = 23 units per MagnaPak Container

⁹ Recommended for installations within 750 feet from coast. Lead time varies, check with factory.

¹⁰ Not available with DALI "U" option

¹¹ Only available with 02 Lumen Code

¹² Not compatible with 02 Lumen Code

Suggested HID Replacement

Approximately 2,000-3,000 lumens to replace 50W-70W HPS Cobra-head

Approximately 4,000-5,000 lumens to replace 100W HPS Cobra-head

Approximately 7,000-9,000 lumens to replace 150W HPS Cobra-head

Approximately 9,000-12,000 lumens to replace 200W HPS Cobra-head

Approximately 12,000-16,000 lumens to replace 250W HPS Cobra-head

Note: actual replacement lumens may vary based upon mounting height, pole spacing, design criteria, etc.

CUSTOMER NAME _____

PROJECT NAME _____

DATE _____ TYPE _____

CATALOG NUMBER _____

LUMEN OUTPUT	DIST.	TYPICAL INITIAL LUMENS			WATTAGE		BUG RATINGS		
		5000K/4000K	3000K	2700K	120V 277V	347V 480V	5000K/4000K	3000K	2700K
02	A5	2000	1900	1900	15*	N/A	B1-U0-G1	B1-U0-G1	B1-U0-G1
	B5						B1-U0-G1	B1-U0-G1	B1-U0-G1
	C5						B1-U0-G1	B0-U0-G1	B0-U0-G1
	D5						B0-U0-G1	B0-U0-G1	B0-U0-G1
	E5						B1-U0-G1	B1-U0-G1	B1-U0-G1
03	A5	3000	2900	2800	22	26	B1-U0-G1	B1-U0-G1	B1-U0-G1
	B5						B1-U0-G1	B1-U0-G1	B1-U0-G1
	C5						B1-U0-G1	B1-U0-G1	B1-U0-G1
	D5						B1-U0-G1	B1-U0-G1	B1-U0-G1
	E5						B1-U0-G1	B1-U0-G1	B1-U0-G1
04	A5	4000	3900	3800	29	33	B1-U0-G1	B1-U0-G1	B1-U0-G1
	B5						B1-U0-G1	B1-U0-G1	B1-U0-G1
	C5						B1-U0-G1	B1-U0-G1	B1-U0-G1
	D5						B1-U0-G1	B1-U0-G1	B1-U0-G1
	E5						B1-U0-G1	B1-U0-G1	B1-U0-G1
05	A5	5000	4900	4700	37	39	B1-U0-G1	B1-U0-G1	B1-U0-G1
	B5						B1-U0-G1	B1-U0-G1	B1-U0-G1
	C5						B1-U0-G1	B1-U0-G1	B1-U0-G1
	D5						B1-U0-G1	B1-U0-G1	B1-U0-G1
	E5						B2-U0-G2	B1-U0-G1	B1-U0-G1
06	A5	6000	5800	5700	46	49	B2-U0-G2	B2-U0-G2	B2-U0-G2
	B5						B1-U0-G1	B1-U0-G1	B1-U0-G1
	C5						B1-U0-G2	B1-U0-G2	B1-U0-G2
	D5						B1-U0-G2	B1-U0-G2	B1-U0-G2
	E5						B2-U0-G2	B2-U0-G2	B2-U0-G2
07	A5	7000	6700	6200	50	51	B2-U0-G2	B2-U0-G2	B2-U0-G2
	B5						B1-U0-G2	B1-U0-G2	B1-U0-G1
	C5						B1-U0-G2	B1-U0-G2	B1-U0-G2
	D5						B1-U0-G2	B1-U0-G2	B1-U0-G2
	E5						B2-U0-G2	B2-U0-G2	B2-U0-G2
08	A5	8000	7600	7100	59		B2-U0-G2	B2-U0-G2	B2-U0-G2
	B5						B2-U0-G2	B2-U0-G2	B1-U0-G2
	C5						B1-U0-G2	B1-U0-G2	B1-U0-G2
	D5						B1-U0-G2	B1-U0-G2	B1-U0-G2
	E5						B2-U0-G2	B2-U0-G2	B2-U0-G2
09	A5	9000	8600	8000	68		B2-U0-G2	B2-U0-G2	B2-U0-G2
	B5						B2-U0-G2	B2-U0-G2	B2-U0-G2
	C5						B1-U0-G2	B1-U0-G2	B1-U0-G2
	D5						B1-U0-G2	B1-U0-G2	B1-U0-G2
	E5						B2-U0-G2	B2-U0-G2	B2-U0-G2

NOTE: * 120-240V only

For additional information on ERL1 IES files, please click one of the following links:

Shielded

CUSTOMER NAME _____

PROJECT NAME _____

DATE _____ TYPE _____

CATALOG NUMBER _____

LUMEN OUTPUT	DIST.	TYPICAL INITIAL LUMENS			WATTAGE		BUG RATINGS		
		5000K/4000K	3000K	2700K	120V 277V	347V 480V	5000K/4000K	3000K	2700K
10	A5	10000	9600	8900	76	B2-U0-G2	B2-U0-G2	B2-U0-G2	
	B5					B2-U0-G2	B2-U0-G2	B2-U0-G2	
	C5					B2-U0-G2	B2-U0-G2	B1-U0-G2	
	D5					B1-U0-G2	B1-U0-G2	B1-U0-G2	
	E5					B3-U0-G3	B2-U0-G2	B2-U0-G2	
11	A5	11000	10500	9700	87	B3-U0-G3	B3-U0-G3	B2-U0-G2	
	B5					B2-U0-G2	B2-U0-G2	B2-U0-G2	
	C5					B2-U0-G2	B2-U0-G2	B2-U0-G2	
	D5					B2-U0-G2	B2-U0-G2	B1-U0-G2	
	E5					B3-U0-G3	B3-U0-G3	B3-U0-G3	
12	A5	12000	11500	11100	93	B3-U0-G3	B3-U0-G3	B3-U0-G3	
	B5					B2-U0-G2	B2-U0-G2	B2-U0-G2	
	C5					B2-U0-G2	B2-U0-G2	B2-U0-G2	
	D5					B2-U0-G2	B2-U0-G2	B2-U0-G2	
	E5					B3-U0-G3	B3-U0-G3	B3-U0-G3	
13	A5	13000	12400	12000	102	B3-U0-G3	B3-U0-G3	B3-U0-G3	
	B5					B2-U0-G2	B2-U0-G2	B2-U0-G2	
	C5					B2-U0-G3	B2-U0-G2	B2-U0-G2	
	D5					B2-U0-G2	B2-U0-G2	B2-U0-G2	
	E5					B3-U0-G3	B3-U0-G3	B3-U0-G3	
14	A5	14000	13400	13000	110	B3-U0-G3	B3-U0-G3	B3-U0-G3	
	B5					B2-U0-G2	B2-U0-G2	B2-U0-G2	
	C5					B2-U0-G3	B2-U0-G3	B2-U0-G3	
	D5					B2-U0-G2	B2-U0-G2	B2-U0-G2	
	E5					B3-U0-G3	B3-U0-G3	B3-U0-G3	
15	A5	15000	14400	13900	121	B3-U0-G3	B3-U0-G3	B3-U0-G3	
	B5					B3-U0-G3	B2-U0-G2	B2-U0-G2	
	C5					B2-U0-G3	B2-U0-G3	B2-U0-G3	
	D5					B2-U0-G2	B2-U0-G2	B2-U0-G2	
	E5					B3-U0-G3	B3-U0-G3	B3-U0-G3	
16	A5	15700	15000	14600	129	B3-U0-G3	B3-U0-G3	B3-U0-G3	
	B5					B3-U0-G3	B3-U0-G3	B2-U0-G2	
	C5					B2-U0-G3	B2-U0-G3	B2-U0-G3	
	D5					B2-U0-G3	B2-U0-G3	B2-U0-G2	
	E5					B3-U0-G3	B3-U0-G3	B3-U0-G3	

For additional information on ERL1 IES files, please click one of the following links:

[Non-Shielded](#)

[Shielded](#)

ERL1
Type II Narrow

15700 Lumens
5000K
ERL1_16A550___IES

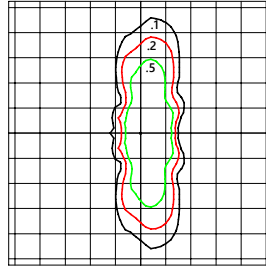

- Mounting Height at 30'
- Initial Footcandle at Grade

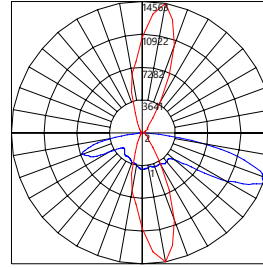

- Vertical plane at max Cd horiz. angle 80°
- Horizontal cone at max Cd vert. angle 68°

ERL1
Type II Wide

15700 Lumens
5000K
ERL1_16B550___IES

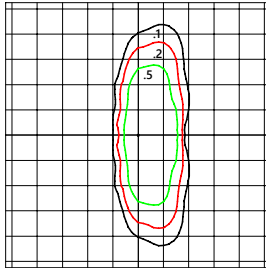

- Mounting Height at 30'
- Initial Footcandle at Grade

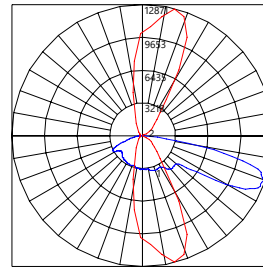

- Vertical plane at max Cd horiz angle 75°
- Horizontal cone at max Cd vert. angle 68°

ERL1
Type III

15700 Lumens
5000K
ERL1_16C550___IES

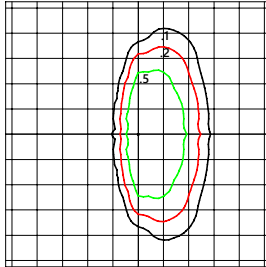

- Mounting Height at 30'
- Initial Footcandle at Grade

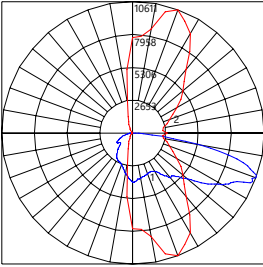

- Vertical plane at max Cd horiz angle 70°
- Horizontal cone at max Cd vert. angle 70°

ERL1
Type IV Short

15700 Lumens
5000K
ERL1_16D550___IES

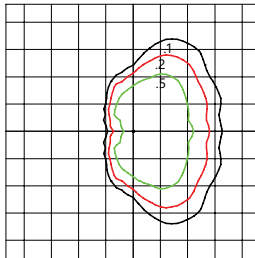

- Mounting Height at 40'
- Initial Footcandle at Grade

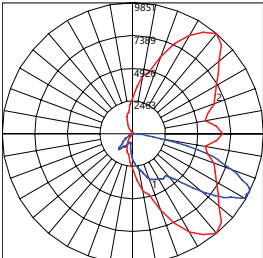

- Vertical plane at max Cd horiz angle 50°
- Horizontal cone at max Cd vert. angle 63°

ERL1
Type II Medium

15700 Lumens
5000K
ERL1_16E550___IES

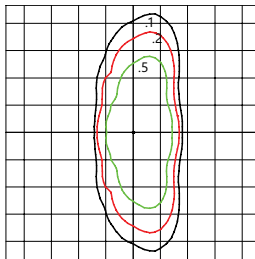

- Mounting Height at 40'
- Initial Footcandle at Grade

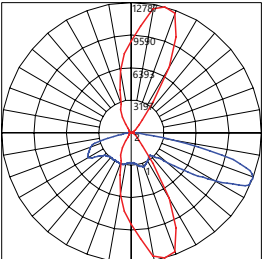

- Vertical plane at max Cd horiz angle 75°
- Horizontal cone at max Cd vert. angle 69°

ISO illuminate diagrams and polar plots are representative of the SKUs illustrated. Refer to IES files for SKU specific information.

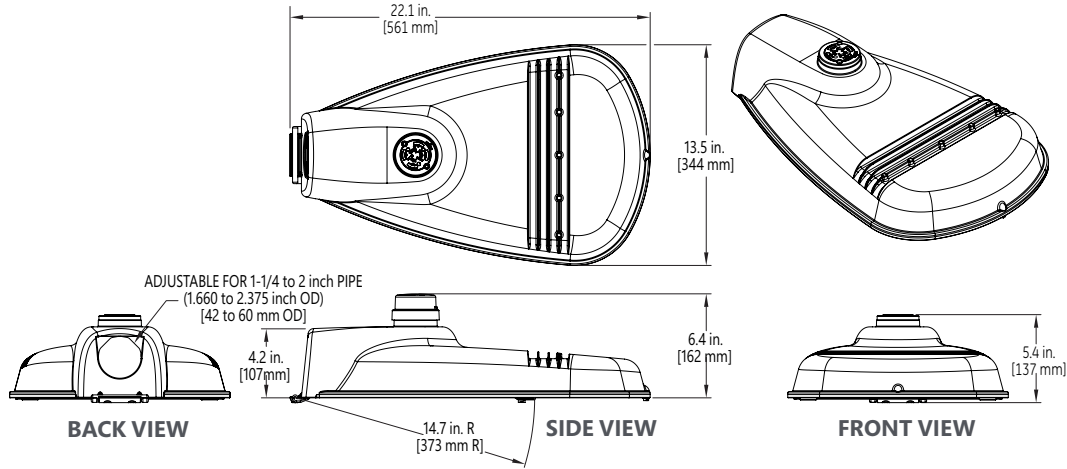

Mounting

- Adjustable for 1.25 to 2 in. nominal mounting pipe (1.660 to 2.375 inch OD)
- Integral diecast mounting pipe stop
- Slipfitter with +/- 5 degrees of leveling adjustment

Effective Projected Area

- 0.5 sq ft max (0.046 sq m)

Weight

- 12.4 lbs (5.6 kgs)

Accessories

SAP Number	Part Number	Description
93029237G	PED-MV-LED-7	ANSI C136.41 Dimming PE, 120-277V
93029238G	PED-347-LED-7	ANSI C136.41 Dimming PE, 347V
93029239G	PED-480-LED-7	ANSI C136.41 Dimming PE, 480V
28299	PECOTL	Long Life PE 120-277V
93147530	PECHTL	Long Life PE 347-480V
73251	SCCL-PECTL	Shorting Cap

Network Lighting Controls



Current's **LightGrid+**™ Outdoor Lighting Control System is designed for Street and Roadway Applications. It enables remote monitoring, control, and asset management of a single fixture or a group of fixtures through a web enabled Central Management System.

CUSTOMER NAME _____

PROJECT NAME _____

DATE _____ TYPE _____

CATALOG NUMBER _____

HOUSE SIDE SHIELDS

ERL1 Shields

Product Code:	93024487G	Description:	ELSHS-ERL1-BLCK
Product Code:	93046386G	Description:	ELSHS-ERL1-GRAY
Product Code:	93068998	Description:	ELSHS-ERL1-DKBZ
			

STREET SIDE SHIELDS

ERL1 Shields

Product Code:	93092595	Description:	ELSFS-ERL1-BLCK-10
Product Code:	93108740G	Description:	ELSFS-ERL1-GRAY-10
Product Code:	93092906	Description:	ELSFS-ERL1-BLCK-15
Product Code:	93105144G	Description:	ELSFS-ERL1-GRAY-15
Product Code:	93088130	Description:	ELSFS-ERL1-BLCK-20
Product Code:	93088131G	Description:	ELSFS-ERL1-GRAY-20
			

SIDE SHIELDS (L&R)

Shipped as a kit - L & R can be used independently

ERL1 SHIELDS

Product Code:	93118695G	Description:	ELS-ERL1H-LEFTRIGHTSIDEKIT-BLCK-10
			

FOOTNOTES:

- 1) 10 = 1" Shield Depth; 15 = 1.5" Shield Depth; 20 = 2" Shield Depth
- 2) Black is recommended to reduce potential for glare coming off of the shield
- 3) Use "House Side" Shield to block light trespass behind the pole
- 4) Use "Street Side" / Front Shield to block light trespass across the street