



CUSTOMER NAME _____
 PROJECT NAME _____
 DATE _____ TYPE _____
 CATALOG NUMBER _____

The Evolve® LED Post Top Town & Country (EPTT) offers energy efficiency and quality of light in a classic look and style. The advanced LED optical system provides improved horizontal and vertical uniformity, reduced glare and improved lighting control.

Construction

Housing:	Aluminum die cast housing and top with traditional lantern design and optional Carriage Top style Cupola compatible with C136.41 PE's, Shorting Caps and LightGrid Nodes
Lens:	Acrylic, Polycarbonate, None/Open
Paint:	Corrosion resistant polyester powder paint, minimum 2.0 mil thickness Standard = Black, Dark Bronze RAL & custom colors available
Weight:	14.5 - 20 lbs (6.6 - 9.1 kg)

Optical System

Lumens:	2,400-10,200
Distribution:	Symmetric Asymmetric
Efficacy (LPW):	102-152
CCT:	2700K, 3000K, 4000K
CRI (Min):	≥70

Electrical

Input Voltage:	120-277V
Input Frequency:	50/60Hz
Power Factor:	≥ 90% at rated watts
Total Harmonic Distortion:	≤ 20% at rated watts

Surge Protection*

STANDARD	OPTIONAL
10kV/5kA	Secondary 10kV/5kA (R Option) Secondary 20kV/10kA (T Option)

*Per ANSI C136.2-2023

Lumen Maintenance

Projected Lxx per IES TM-21-11 at 25°C

WATTAGE CODES	LXX(≥17K) @ HOURS			
	25,000 HR	50,000 HR	75,000 HR	100,000 HR
02, 03, 04, 05, 06	98	96	93	91
07, 08	97	95	92	90

Note: Projected Lxx based on LM80 (≥ 10,000 hour testing). Accepted industry tolerances apply to initial luminous flux and lumen maintenance measurements.

Ambient Temperature Factor

AMBIENT TEMP (°C)	INITIAL FLUX FACTOR	AMBIENT TEMP (°C)	INITIAL FLUX FACTOR
10	1.02	30	0.99
20	1.01	40	0.98
25	1.00	50	0.97

Ratings

	Range	Wattage Code
Operating Temp:	-40°C to 50°C:	02-07
	-40°C to 45°C:	08
Vibration:	3G per ANSI C136.31-2018	
LM-79:	Tested in accordance with IES Standards	
EMI:	FCC Title 47 CFR part 15 Class A	
RoHS:	Complies with the material restrictions of RoHS	

Controls

Dimming:	Standard - 0-10V Optional - DALI D4i (U4 Option)
Sensors:	Photo Electric Sensors (PE) available LightGrid™ Compatible

Warranty

5 Year (Standard)

10 Year (Optional)



CUSTOMER NAME	_____
PROJECT NAME	_____
DATE	_____ TYPE _____
CATALOG NUMBER	_____

Ordering Information

EPTT 03

PROD. ID	GEN	VOLTAGE	WATT CODE	DISTRIBUTION	REFRACTOR	CCT	RECEPTACLE ^{1,2,3}	TOP STYLE	FINISH	OPTIONS
E = Evolve	03	0 = 120-277V	02	A = Symmetric	A = Acrylic	27 = 2700K	A = ANSI 7-Pin	P = Traditional	BLCK = Black	L = Tool-Less Entry
P = Post Top			03	B = Asymmetric	P = Polycarbonate	30 = 3000K	D = ANSI 7-Pin w/ Shrt Cap	C = Carriage	DKBZ = Dark Bronze	P06 = Prewire with 6 ft of 14/3 Cable
TT = Town & Country Traditional			04	N = None	40 = 4000K	E = ANSI 7-Pin w/ Long Life PE				R = 10kV/5kA Secondary SPD
			05							T = 20kV/10kA Secondary SPD
			06							U4 = DALI D4i Programmable ^{2,3,4}
			07							V1 = Field Adjustable Module ⁴
			08							Y = Coastal Finish ⁵

¹ 7-Pin receptacles per ANSI C136.41.
² 7 Pin receptacle wired for 0-10V control unless DalI (U4) selected.
³ If U4 option is selected and A, D or E (7-Pin) receptacle option is selected, the D4i driver is configured with the DALI Integrated Power BUS enabled. Contact factory if DALI is desired with Integrated Power BUS disabled.
⁴ Field Adjustable Module (option V1) not available with DalI (Option U4).
⁵ Coastal Finish (option Y) is recommended for installations within 750 feet from coast. Lead time varies, check with factory.



Traditional
Open/No Refractor



Traditional
Acrylic or Polycarbonate Refractor



Carriage
Open/No Refractor



Carriage
Acrylic or Polycarbonate Refractor

CUSTOMER NAME _____

PROJECT NAME _____

DATE _____

TYPE _____

CATALOG NUMBER _____

WATTAGE CODE	DISTRIBUTION	GLOBE TYPE	INITIAL LUMENS			TYPICAL WATTAGE		BUG RATINGS		
			4000K	3000K	2700K	120-277V	LPW*	4000K	3000K	2700K
02	A	N	3600	3450	3160	25	147	B2-U0-G1	B2-U0-G1	B2-U0-G1
	B		3470	3330	3050		142	B1-U0-G1	B1-U0-G1	B1-U0-G1
	A	A	3200	3070	2810		131	B2-U3-G2	B2-U3-G2	B2-U3-G2
	B		3030	2900	2660		124	B1-U3-G2	B1-U3-G2	B1-U3-G2
	A	P	2840	2720	2490		116	B2-U3-G2	B2-U3-G2	B2-U3-G2
	B		2730	2620	2400		112	B1-U3-G2	B1-U3-G2	B1-U3-G2
03	A	N	4350	4170	3820	30	152	B3-U0-G1	B3-U0-G1	B2-U0-G1
	B		4190	4020	3680		147	B1-U0-G1	B1-U0-G1	B1-U0-G1
	A	A	3870	3710	3400		136	B2-U3-G2	B2-U3-G2	B2-U3-G2
	B		3670	3520	3220		129	B1-U3-G2	B1-U3-G2	B1-U3-G2
	A	P	3430	3290	3010		120	B2-U3-G2	B2-U3-G2	B2-U3-G2
	B		3300	3160	2900		116	B1-U3-G2	B1-U3-G2	B1-U3-G2
04	A	N	5750	5520	5060	40	150	B3-U0-G1	B3-U0-G1	B3-U0-G1
	B		5540	5310	4870		144	B2-U0-G2	B2-U0-G2	B1-U0-G2
	A	A	5110	4900	4490		133	B2-U3-G2	B2-U3-G2	B2-U3-G2
	B		4850	4650	4260		127	B2-U3-G3	B2-U3-G3	B2-U3-G3
	A	P	4540	4350	3990		118	B2-U3-G2	B2-U3-G2	B2-U3-G2
	B		4370	4190	3840		114	B2-U3-G2	B2-U3-G2	B1-U3-G2
05	A	N	7000	6720	6160	50	146	B3-U0-G1	B3-U0-G1	B3-U0-G1
	B		6750	6480	5940		141	B2-U0-G2	B2-U0-G2	B2-U0-G2
	A	A	6230	5980	5480		130	B3-U3-G3	B3-U3-G3	B3-U3-G3
	B		5900	5660	5190		123	B2-U3-G3	B2-U3-G3	B2-U3-G3
	A	P	5530	5300	4860		115	B3-U3-G3	B3-U3-G3	B3-U3-G3
	B		5320	5100	4680		111	B2-U3-G3	B2-U3-G2	B2-U3-G2
06	A	N	8050	7720	7080	60	139	B3-U0-G2	B3-U0-G2	B3-U0-G1
	B		7760	7440	6820		134	B2-U0-G2	B2-U0-G2	B2-U0-G2
	A	A	7160	6870	6300		124	B3-U3-G3	B3-U3-G3	B3-U3-G3
	B		6790	6510	5970		117	B2-U3-G3	B2-U3-G3	B2-U3-G3
	A	P	6350	6090	5580		110	B3-U3-G3	B3-U3-G3	B3-U3-G3
	B		6110	5860	5370		106	B2-U3-G3	B2-U3-G3	B2-U3-G3
07	A	N	9250	8880	8140	70	135	B3-U0-G2	B3-U0-G2	B3-U0-G2
	B		8920	8560	7840		130	B2-U0-G2	B2-U0-G2	B2-U0-G2
	A	A	8230	7900	7240		120	B3-U4-G3	B3-U4-G3	B3-U3-G3
	B		7800	7480	6860		114	B2-U3-G3	B2-U3-G3	B2-U3-G3
	A	P	7300	7000	6420		107	B3-U3-G3	B3-U3-G3	B3-U3-G3
	B		7030	6740	6180		104	B2-U3-G3	B2-U3-G3	B2-U3-G3
08	A	N	10200	9790	8970	80	134	B3-U0-G2	B3-U0-G2	B3-U0-G2
	B		9840	9440	8650		129	B2-U0-G2	B2-U0-G2	B2-U0-G2
	A	A	9070	8700	7980		119	B3-U4-G3	B3-U4-G3	B3-U4-G3
	B		8600	8250	7560		113	B3-U4-G3	B2-U4-G3	B2-U3-G3
	A	P	8050	7720	7080		106	B3-U3-G3	B3-U3-G3	B3-U3-G3
	B		7750	7440	6820		102	B3-U3-G 3	B2-U3-G3	B2-U3-G3

*LPW based on 120-277v, 0-10v dimming, & 4000K CCT (utilizing non-rounded lumens & watts)

CUSTOMER NAME _____

PROJECT NAME _____

DATE _____

TYPE _____

CATALOG NUMBER _____

EPTT

Symmetric (Acrylic Refractor)
9,070 Lumens
4,000K
EPTT03_08AA40____.IES

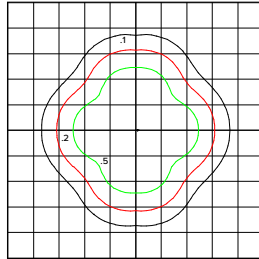

- Grid Distance in Units of Mounting Height at 16'
- Initial Footcandle Values at Grade

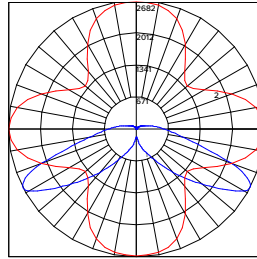

- Vertical plane through horizontal angle of Max. Cd at 90°
- Horizontal cone through vertical angle of Max. Cd at 58°

EPTT

Asymmetric (Acrylic Refractor)
8,600 Lumens
4,000K
EPTT03_08BA40____.IES

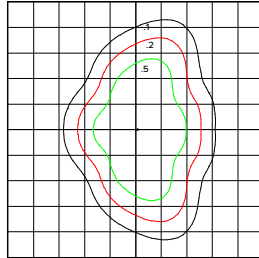

- Grid Distance in Units of Mounting Height at 16'
- Initial Footcandle Values at Grade

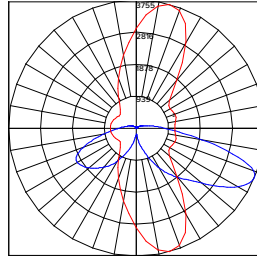

- Vertical plane through horizontal angle of Max. Cd at 75°
- Horizontal cone through vertical angle of Max. Cd at 69°

EPTT

Symmetric (No Refractor)
10,200 Lumens
4,000K
EPTT03_08AN40____.IES

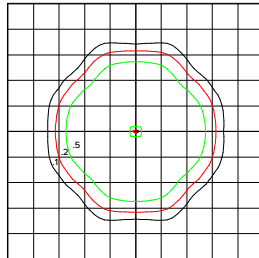

- Grid Distance in Units of Mounting Height at 16'

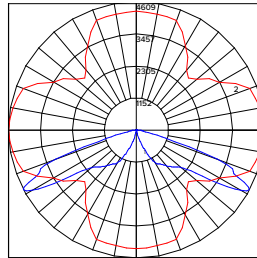

- Vertical plane through horizontal angle of Max. Cd at 5°
- Horizontal cone through vertical angle of Max. Cd at 62°

EPTT

Asymmetric (No Refractor)
9,840 Lumens
4,000K
EPTT03_08BN40____.IES

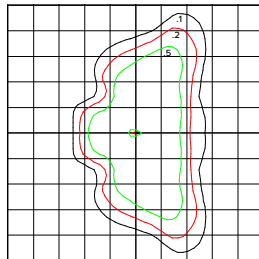

- Grid Distance in Units of Mounting Height at 16'

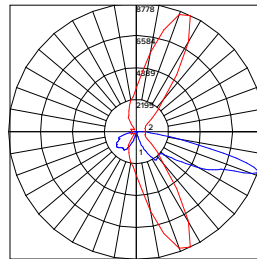

- Vertical plane through horizontal angle of Max. Cd at 70°
- Horizontal cone through vertical

EPTT

Symmetric (Poly Refractor)
8,050 Lumens
4,000K
EPTT03_08AP40____.IES

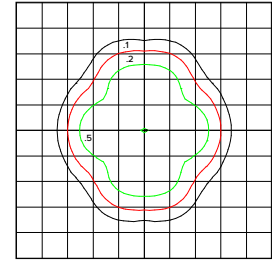

- Grid Distance in Units of Mounting Height at 16'
- Initial Footcandle Values at Grade

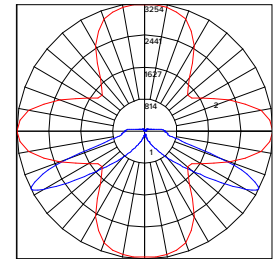

- Vertical plane through horizontal angle of Max. Cd at 80°
- Horizontal cone through vertical angle of Max. Cd at 60°

EPTT

Asymmetric (Poly Refractor)
7,750 Lumens
4,000K
EPTT03_08BP40____.IES

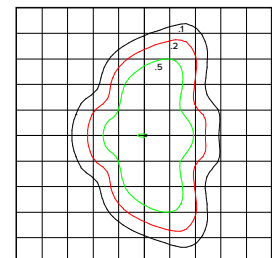

- Grid Distance in Units of Mounting Height at 16'
- Initial Footcandle Values at Grade

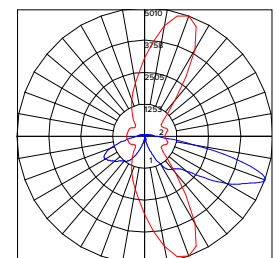

- Vertical plane through horizontal angle of Max. Cd at 75°
- Horizontal cone through vertical angle of Max. Cd at 71°

CUSTOMER NAME _____
 PROJECT NAME _____
 DATE _____ TYPE _____
 CATALOG NUMBER _____

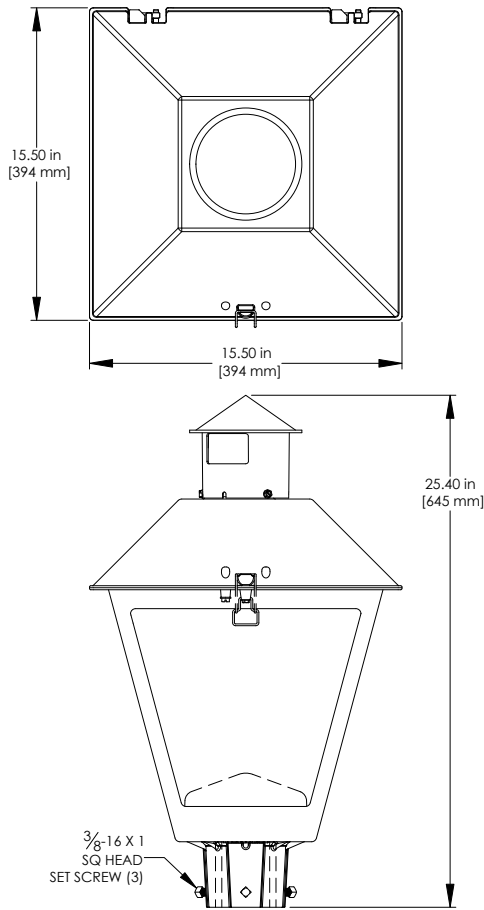

TRADITIONAL TOP

Mounting

- Mounts to 2-3/8 to 3-inch (60-76mm) OD vertical tenon
- Suggested Mounting Height = 8-18 ft. (2.5 - 5.5M)

Effective Projected Area

- 1.6 sq. ft. max (0.15 sq M max)

Weight

- 14.5 - 20lbs (6.6 - 9.1 kgs)

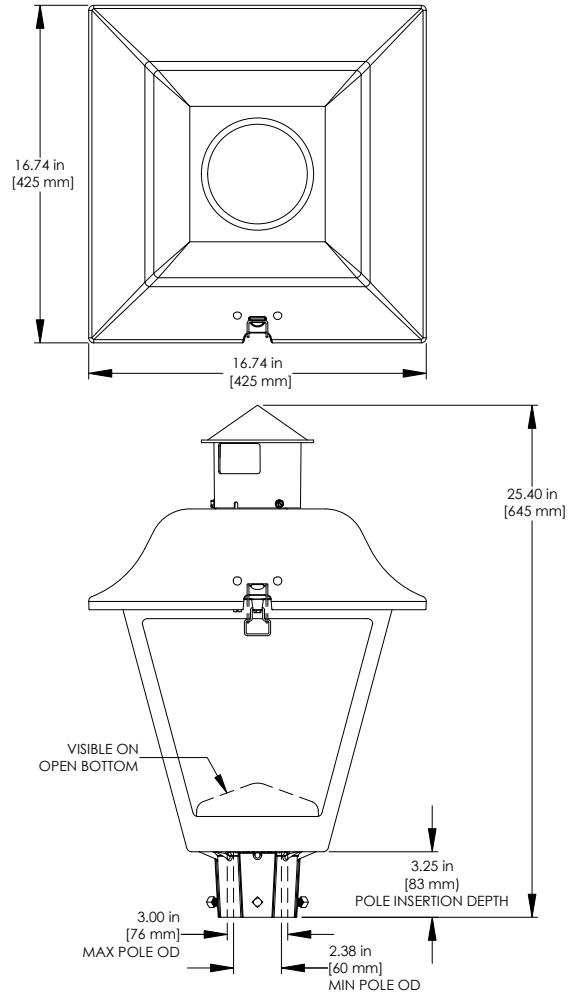

CARRIAGE TOP

EPTT House Side Shields

PART NUMBER	DESCRIPTION
LSPX-TT	Perforated Shield for Open Sided or Refractor Designs
LSSX-TT	Solid "Black" Shield for Open Sided or Refractor Designs

Network Lighting Controls



Current's LightGrid™ Outdoor Lighting Control System is designed for Street and Roadway Applications. It enables remote monitoring, control, and asset management of a single fixture or a group of fixtures through a web enabled Central Management System.