



GTX[®]

City ELA Model LED Arrow Signals

12 inch

Incandescent look (120V)



Project Name _____

Date _____ Type _____

Notes _____

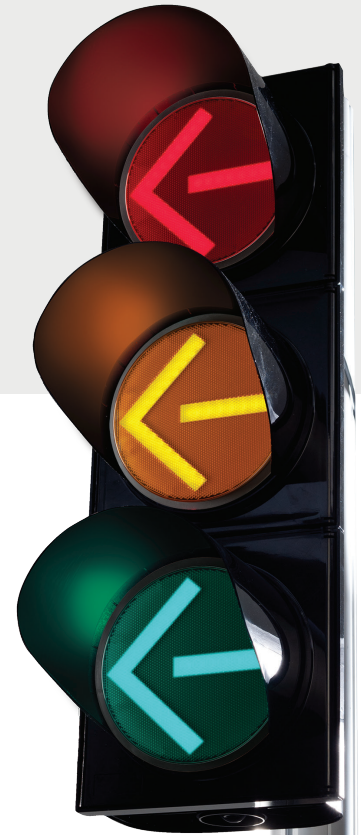

BUILT TO LAST

- Robust thermal management for longer life
- Optimized opto-electrical system for long lifetimes and extreme field temperature conditions

OUTSTANDING RELIABILITY & ROBUST OPERATION

- High efficiency and high-brightness LED light source
- Failed state impedance protection detects the loss of LED load
- Optimized thermal management for longer life
- Provides performance under extreme field temperature conditions

MEETS RIGOROUS CERTIFICATION & TESTING STANDARDS

- Intertek ETL Verified compliant
- DOE compliant
- CSA approved model available
- Using MIL-STD-810F and MIL-STD-883 for environmental robustness, passed reliability and qualification testing, including high temperature, high humidity cycling
- Compliant with ITE VTCSH LED Vehicle Arrow Traffic Signal Supplement dated July 1, 2007



The Greatest Signals Stand the Test of Time.™



GTX[®] City ELA Model LED Arrow Signals

12 inch

Project Name _____

Date _____ Type _____

Notes _____

Mechanical Outline Dimensions in inches (mm)

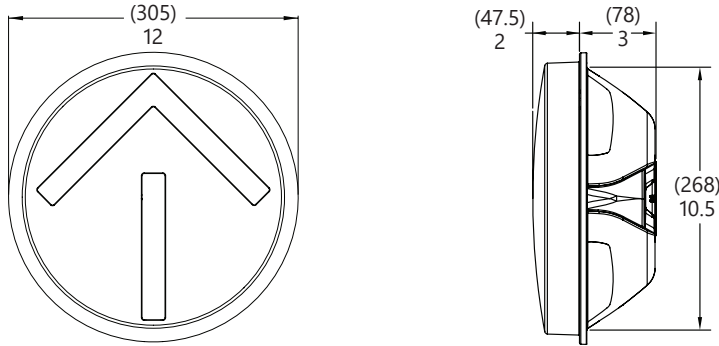

Operating Specifications

Parameter	Rating
Operating Temperature Range*	-40 to +74°C (-40 to +165°F)
Operating Voltage Range	80 to 135 V (60Hz AC)
Power Factor (PF)	> 90 %
Total Harmonic Distortion (THD)	< 20 %
Voltage Turn-Off (VTO)	35 V
Turn-On/Turn-Off Time	< 75msec
Lens & Shell Material	UV Stabilized Polycarbonate
Wiring	40in, 20 AWG, Color Coded with Strain Relief

* Operating Temperature Range per ITE 2005 section 3.3.2

Design Compliance

Test type	Compliance
Luminous Intensity	ITE VTCSH-LED Vehicle Arrow Traffic Signal Supplement, July 2007
Chromaticity	ITE VTCSH-LED Vehicle Arrow Traffic Signal Supplement, July 2007
Moisture Resistance	NEMA STD 250 Type 4 – 1991 Blown Wind Rain MIL-STD-810F method 506.4
Mechanical Vibration	MIL-STD-883 Method 2007
Electronic Noise	CC Title 47 Sub. B Sec.15 ¹
Transient Voltage Protection	Sec. 2.1.6 NEMA TS2-2003, 300V, 2500W Sec. 2.1.6 NEMA TS2-2003, 600V, 10µF Sec. 2.1.8 NEMA TS2-2003
Controller Compatibility	ITE VTCSH-LED Vehicle Arrow Traffic Signal Supplement, July 2007
Wiring	NFPA 70, National Electric Code
Transient Suppression	Sec. 8.2 IEC 1000-4-5 & Sec. 6.1.2 ANSI/IEEE C62.41.2 - 2002, 3KV, 2Ω Sec. 8.0 IEC 1000-4-12 & Sec. 6.1.1 ANSI/IEEE C62.41.2 - 2002, 6KV, 30Ω
Immunity	Radiated electromagnetic field immunity - radio frequencies IEC 6100-4-3:2020 10 V/m (80 MHz-1 GHz) – Class A

Product Information

Model Number	Size (in)	AC Voltage Nominal	Power (W) Nominal	Wavelength (nm) Dominant	Maintained Intensity (cd) Minimum
● DR6-RTAAN-ELA	12	120V – 60Hz	5.5	625	59
○ DR6-RCAAN-ELA	12	120V – 60Hz	5.5	625	59
● DR6-YTAAAN-ELA	12	120V – 60Hz	5.7	589	146
○ DR6-YCAAN-ELA	12	120V – 60Hz	6.7	589	146
● DR6-GTAAAN-ELA	12	120V – 60Hz	5.8	500	76
○ DR6-GCAAN-ELA	12	120V – 60Hz	8.3	500	76

Distributed by:

All lamps available in tinted or clear lens.

¹ Class A