



LED40W-LT Series

Line Voltage Dimmable



Electrical Specifications

Input Voltage Range:	120V model: 108-132V Min/Max 230V model: 208-300V Min/Max
Frequency:	50/60 Hz Nom. (47-63 Hz Min/Max)
Power Factor:	> 0.90 at Rated Vac, Full Load, no dimmer
Inrush Current:	<15.0 Amps @ 120Vac, cold start 25°C, max load
Input Current:	0.39 Amps @ 120Vac, 60Hz, max load
Maximum Power:	40W
Line Regulation:	± 3%
Load Regulation:	± 5%

Protections

Over-voltage:	No Damage, Auto Recovery after fault is removed
Over-current:	Constant Current Limiting Circuit
Short Circuit:	No Damage, Auto Recovery after fault is removed

Environmental Specifications

Max Case Life Temp:	58°C (5 year warranty)
Maximum Case Temp (UL):	85°C
Minimum Starting Temp:	-30°C
Storage Temperature:	-40°C to +85°C
Humidity:	5% to 95%
Cooling:	Convection
Vibration Frequency:	5 to 55 Hz/2g, 30 minutes
Sound Rating:	Class A
Impact Resistance:	1g/s
MTBF:	375,000 Hours @ full load & 40°C ambient conditions per MIL-217F Notice 2
EMC:	FCC 47CFR Part 15 Class B @ 120Vac, Class A @ 230/277Vac
Weight:	11 oz (311 g)

- Total Power: 40 Watts
- 0%-100% (depends on dimmer control)
- Models For: 120Vac or 220Vac-277Vac Input
- Both ELV & Inc in the same unit
- UL Dry & Damp Location Rated
- IP66 & NEMA4
- High Power Factor
- Black Magic Thermal Advantage™ Plastic Housing
- Compatible with Triac (leading edge) and ELV (electronic low voltage; trailing edge) dimmer controls
- Use a dimmer that closely matches the load, just slightly larger. (EX: For best performance, use a 150W rated dimmer for 100W total LED load instead of 600W dimmer.)

Note: LED drivers are designed and intended to operate LED loads only. Non-LED loading may be outside the specified design limits of our LED drivers, and therefore cannot be covered by any warranty. If you desire to use our LED drivers to operate non-LED loads please contact us to discuss compatibility.



120Vac Model - ELV & INC Dimming Specifications

Model	Output Current (mA ±5%)	Output Voltage Range (Vdc)	Max. Output Power (W)	Typical Efficiency
LED40W120-114-C0350-LT	350	72-114	40	85%
LED40W120-054-C0700-LT	700	34-54	40	85%
LED40W120-040-C1000-LT	1000	25-40	40	84%
LED40W120-036-C1100-LT	1100	22-36	40	84%
LED40W120-030-C1300-LT	1300	19-30	40	83%
LED40W120-024-C1670-LT	1670	15-24	40	82%

230Vac Model - ELV & INC Dimming Specifications

Model	Output Current (mA ±5%)	Output Voltage Range (Vdc)	Max. Output Power (W)	Typical Efficiency
LED40W230-114-C0350-LT	350	72-114	40	86%
LED40W230-054-C0700-LT	700	34-54	40	86%
LED40W230-040-C1000-LT	1000	25-40	40	85%
LED40W230-036-C1100-LT	1100	22-36	40	85%
LED40W230-030-C1300-LT	1300	19-30	40	84%
LED40W230-024-C1670-LT	1670	15-24	40	83%

Class 2: US/Canada

Safety Cert. Standard

UL/CUL	UL8750
CSA	22.2
CE	EN61347

EMC Standard Notes

EN 61000-3-2	
EN 61000-3-3	Class C
FCC, 47 CFR Part 15	Class B @ 120Vac, Class A @ 230/277Vac
EN 61000-4-5	2KV L-N, 8/20 µsec Surge Protection

Dimensions

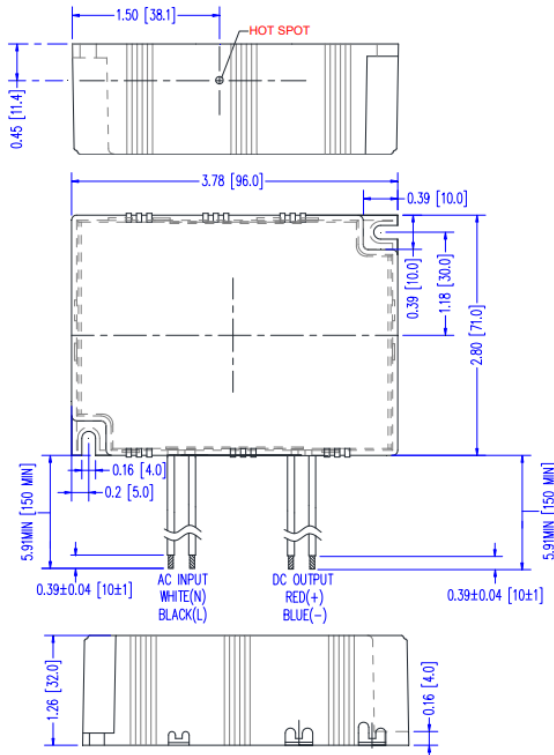

IN [mm]

WIRE SPECS:

Input Leads: 18 AWG, rated 600 V, 105C, min.
Output Leads: 18 AWG, rated 300 V, 105C, min.
All wires are stranded with solder dipped ends.

Power Characteristics

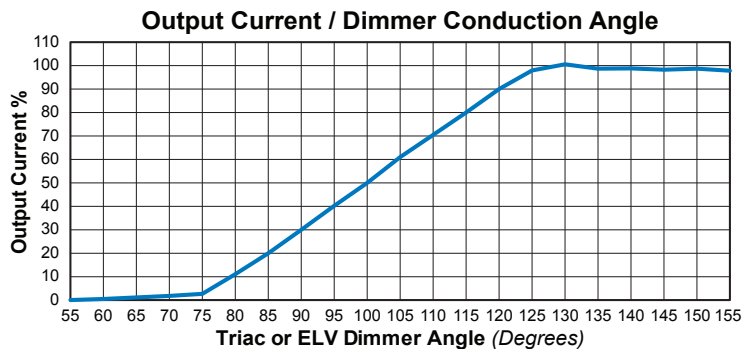
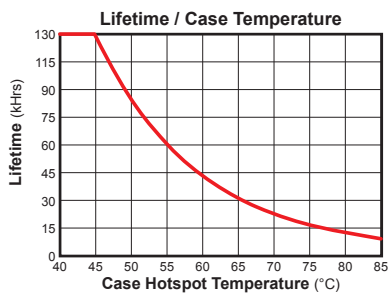
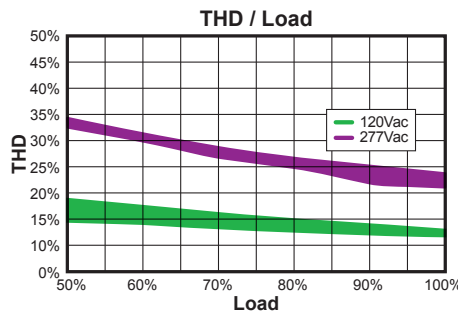
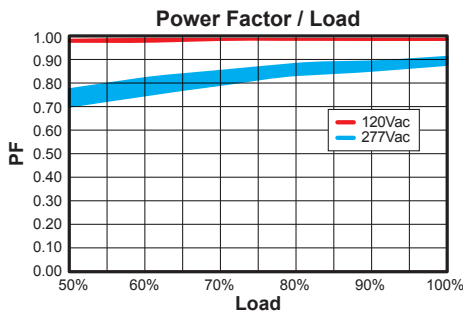

Note: The area under the life-temperature curve represents where the driver has highly reliable operation within specification. Driver performance may drift out of published specifications as the hours of operation exceed the curve at a given temperature. Higher operating temperatures increase the chances of a failure to function. Other electrical, mechanical and environmental factors affect driver lifetime but are not represented in this calculation.

UL Conditions of Acceptability

See website for additional information