

DATE:	LOCATION:
TYPE:	PROJECT:
CATALOG #:	

FEATURES

- Reliable, uniform, glare free illumination
- Types 1, 2, 3, 4W, 5Q, and 5W distributions
- Amber, 3000K, 4000K, 5000K CCT
- 0-10V dimming ready
- Integral Surge protection: 10k in parallel, 20k in series
- Upgrade Kits

PROVIDENCE®



Providence Large



3000K and warmer CCTs only

See Certification Specifications

SPECIFICATIONS

CONSTRUCTION

- All housing components aluminum 360 alloy, sealed with continuous silicone rubber gaskets
- Standard configurations do not require a flat lens, optional lenses are tempered glass
- All internal and external hardware is stainless steel
- Finish: fade and abrasion resistant, electrostatically applied, thermally cured, triglycidal isocyanurate (TGIC) polyester powdercoat
- Optical bezel finish to match the luminaire housing

LED/OPTICS

- Optical cartridge system consisting of a die cast heat sink, LED engine, TIR optics, gasket and bezel plate
- Optics are held in place without the use of adhesives
- Molded silicone gasket ensures a weather-proof seal around each individual LED.
- Features individual LED optical control based on high performance TIR optical designs.
- House Side Shield is available on Standard and Clear Lens options except any Type 5 distribution. House Side Shield is not available for any distribution using a Diffused Lens.

INSTALLATION

- Fixtures must be grounded in accordance with national, state and/or local electrical codes. Failure to do so may result in serious personal injury.

ELECTRICAL

- Luminaires have UL recognized integral surge protection, and have a surge current rating of 10,000 Amps using the industry standard 8/20uSec wave and surge rating of 372J
- Drivers are UL recognized with an inrush current maximum of <20.0 Amps maximum at 230VAC
- 100%-1% dimming range. Fixture will be wired for low voltage 0-10V dimming control

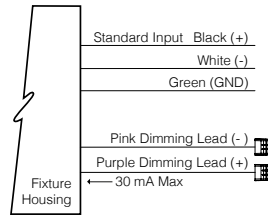

- Driver and surge suppressor are mounted to a prewired tray with quick disconnects that may be removed from the gear compartment
- Surge protection: 10,000k in parallel, 20,000k in series

CONTROLS

- Egress adapter(s) will slip over a 4"/100mm DIA. pole with the luminaire or arm slipping over the adapter to add a total of 4.5"/114mm to the overall height. Adapter(s) are prewired, independently rotatable 359°, and have a cast access cover with an integral lens and lanyard

CONTROLS (CONTINUED)

- Egress adapter will require an auxiliary 120 volt supply for operation of an integral MR16 lamp in the event of emergency. The lamp may be aimed and locked into position with an adjustment range of 15°-45°. Adapter will have a socket that accepts miniature bi-pin MR16 lamps up to 50 watts, lamp by others
- Photocell adapter includes a 7-Pin internal twist lock receptacle. Photocell by others.

CERTIFICATIONS

- ETL listed under UL 1598 and CSA C22.2 No. 250.0-08 for wet locations
- This product qualifies as a "designated country construction material" per FAR 52.225-11 Buy American-Construction Materials under Trade Agreements effective 5/29/2020.

WARRANTY

- 5 year warranty

KEY DATA	
LUMEN RANGE	2,087–17,415
WATTAGE RANGE	60.51–159.8
EFFICACY RANGE (LPW)	29–125.5
INPUT CURRENT RANGE (mA)	270/500/700 mA
WEIGHT	47 lbs / 21.3 kg
EPA	1.33

ORDERING GUIDE

Example: PROL2-72L-325-3K7-4W-BL-SLA1-DF-HS-AD5-UNV

CATALOG #

HOUSING

PROL2		LED Quantity		Lumen Output		CCT/CRI		Distribution		Finish	
PROL2	Providence Large 2.0	72L	72 LED	270	450mA Microcore Equivalent	AMB	Amber-595nm Peak ¹	1	Type I	BLS	Black Gloss Smooth
				335	335mA, 9000 Lumens	3K7	3000K, 70 CRI	2	Type II	BLT	Black Matte Textured
				425	700mA Microcore Equivalent	4K7	4000K, 70 CRI	3	Type III	DBS	Dark Bronze Gloss Smooth
				500	500mA, 13000 Lumens	5K7	5000K, 70 CRI	4W	Type IV Wide	DBT	Dark Bronze Matte Textured
				700	700mA, 17000 Lumens	Contact factory for options listed below		5Q	Type V Square	GTT	Graphite Matte Textured
				27K8	2700K, 80 CRI			5W	Type V Wide	LGS	Light Grey Gloss Smooth
					80 or 90 CRI for standard color temperatures					LGT	Light Grey Matte Textured
										PSS	Platinum Silver Gloss Smooth
										VGT	Verde Green Matte Textured
										WHS	White Gloss Smooth
										WHT	White Matte Textured
										Color Option	
										CC ²	Custom Color

Mounting	Optional Lens	Options	Mounting Options	Voltage
Pole Mount	CL Clear Lens	HS House Side Shield ³	PCA-C Photocontrol Adaptor Contemporary	UNV 120-277V
STND_MNT ⁶ Standard Mount	DL Diffused Lens ²	PFN Brass Colored Finish	EPA-C Egress Adaptor Contemporary	
PT23 2 3/8" tenon		SPK Cast Spikes		
PT3 3" tenon		BPS Brass Colored Struts		
PT4 Slips Over A 4" OD Pole		SF Single Fuse (120, 277)		
Arm Mount		DF Double Fuse (208, 240)		
SLA1 4" pole or tenon				
TRA5U-4 4" pole or tenon				
TRA6U-4 4" pole or tenon				
TRA8U-4 4" pole or tenon				
TRA55-4 4" pole or tenon				
TRA5U-5 5" pole or tenon				
TRA6U-5 5" pole or tenon				
TRA8U-5 5" pole or tenon				
TRA55-5 5" pole or tenon				
TRA56-5 5" pole or tenon				
Wall Mount				
WMA55 Wall Mount				
WMA56 Wall Mount				
Pier Mount				
PM1 Pier Mount 1				
PM2 Pier Mount 2				
PM3 Pier Mount 3				

DIMENSIONS

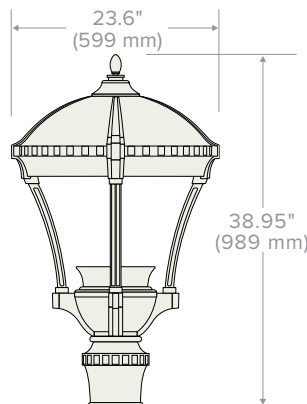

Notes:

- 1 Turtle friendly
- 2 Diffused Lens is available only with T3 and T5W distribution
- 3 House side Shield is available only with T1, T2, T3 and T4W distributions
- 4 Consult factory for custom color, marine and corrosive finish options
- 5 Contact Factory for additional glare shield options
- 6 Slips over 5" OD Pole

DELIVERED LUMENS

The table below shows the delivered lumens for the various lumen outputs and beam distributions. Use this chart in connection with the lumen factor (LF) capability to deliver any output required.

LED #	Drive Current	Lumen Package	Lens	Distribution	3000K 70CRI				4000K 70CRI				5000K 70CRI							
					Lumen	Bug Rating			Efficacy (Lm/W)	Lumen	Bug Rating			Efficacy (Lm/W)	Lumen	Bug Rating			Efficacy (Lm/W)	
72	270	450mA Microcore Equivalent	None	1	7028	1	0	1	116.1	7277	1	0	1	120.3	7533	1	0	1	124.5	
				2	6764	1	0	2	111.8	7004	1	0	2	115.8	7251	1	0	2	119.8	
				3	6824	1	0	2	112.8	7066	1	0	2	116.8	7315	1	0	2	120.9	
				4W	6898	1	0	2	114.0	7143	1	0	2	118.0	7394	1	0	2	122.2	
				1-HS	3806	0	0	1	62.9	3941	0	0	1	65.1	4079	0	0	1	67.4	
				2-HS	3144	0	0	1	52.0	3255	0	0	1	53.8	3370	0	0	1	55.7	
				3-HS	3191	0	0	1	52.7	3305	0	0	1	54.6	3421	0	0	1	56.5	
			4W-HS	2782	0	0	1	46.0	2881	0	0	1	47.6	2982	0	0	1	49.3		
			5Q	7322	3	0	1	121.0	7582	3	0	1	125.3	7849	3	0	1	129.7		
			5W	6904	3	0	1	114.1	7149	3	0	2	118.2	7401	3	0	2	122.3		
			Clear	1-CL	5271	1	0	1	87.1	5458	1	0	1	90.2	5650	1	0	1	93.4	
				2-CL	5073	1	0	1	83.9	5253	1	0	1	86.8	5438	1	0	1	89.9	
				3-CL	5118	1	0	2	84.6	5300	1	0	2	87.6	5486	1	0	2	90.7	
				4W-CL	5174	1	0	2	85.5	5357	1	0	2	88.5	5546	1	0	2	91.7	
	1-CL-HS	2854		0	0	1	47.2	2955	0	0	1	48.8	3059	0	0	1	50.6			
	2-CL-HS	2358		0	0	1	39.0	2441	0	0	1	40.4	2527	0	0	1	41.8			
	3-CL-HS	2393		0	0	1	39.6	2478	0	0	1	41.0	2566	0	0	1	42.4			
	4W-CL-HS	2087	0	0	1	34.5	2161	0	0	1	35.7	2237	0	0	1	37.0				
	5Q-CL	5491	2	0	1	90.8	5686	2	0	1	94.0	5886	2	0	1	97.3				
	5W-CL	5178	3	0	1	85.6	5362	3	0	1	88.6	5550	3	0	1	91.7				
	Diffused	3-DL	4218	1	0	1	55.7	4368	1	0	1	57.7	4521	1	0	1	74.7			
		5W-DL	4268	2	0	1	56.4	4419	2	0	1	58.4	4574	2	0	1	75.6			
	335	9000		None	1	8507	1	0	1	112.4	8809	1	0	1	116.4	9119	1	0	1	119.9
					2	8188	2	0	2	108.2	8479	2	0	2	112.0	8777	2	0	2	116.0
					3	8261	1	0	2	109.4	8554	1	0	2	113.3	8855	2	0	2	116.4
					4W	8351	1	0	2	110.3	8647	1	0	2	114.2	8951	1	0	2	117.5
					1-HS	4607	0	0	1	60.9	4770	0	0	1	63.0	4938	0	0	1	65.1
					2-HS	3805	0	0	1	50.3	3940	0	0	1	52.1	4079	0	0	1	54.1
3-HS					3863	0	0	1	51.0	4000	0	0	1	52.8	4141	0	0	1	54.9	
4W-HS				3368	0	0	1	44.5	3487	0	0	1	46.1	3610	0	0	1	47.8		
5Q				8864	3	0	1	117.1	9178	3	0	1	121.3	9501	3	0	1	125.5		
5W				8358	3	0	2	110.4	8654	3	0	2	114.3	8959	3	0	2	118.6		
Clear				1-CL	6380	1	0	1	84.3	6607	1	0	1	87.3	6839	1	0	1	90.3	
				2-CL	6141	1	0	1	81.1	6359	1	0	1	84.0	6583	1	0	1	87.0	
				3-CL	6196	1	0	2	81.8	6415	1	0	2	84.7	6641	1	0	2	88.1	
				4W-CL	6263	1	0	2	82.7	6485	1	0	2	85.7	6713	1	0	2	88.7	
	1-CL-HS	3455	0	0	1	45.6	3577	0	0	1	47.3	3703	0	0	1	48.9				
	2-CL-HS	2854	0	0	1	37.7	2955	0	0	1	39.0	3059	0	0	1	40.4				
	3-CL-HS	2897	0	0	1	38.3	3000	0	0	1	39.6	3106	0	0	1	41.0				
4W-CL-HS	2526	0	0	1	33.4	2615	0	0	1	34.5	2707	0	0	1	35.8					
5Q-CL	6647	3	0	1	87.8	6883	3	0	1	90.9	7125	3	0	1	94.1					
5W-CL	6268	3	0	1	82.8	6491	3	0	1	85.7	6719	3	0	1	88.8					
Diffused	3-DL	5064	1	0	1	66.9	5243	1	0	1	69.3	5428	1	0	1	71.7				
	5W-DL	5208	2	0	1	68.8	5393	2	0	1	71.2	5583	2	0	1	73.9				

DELIVERED LUMENS

The table below shows the delivered lumens for the various lumen outputs and beam distributions. Use this chart in connection with the lumen factor (LF) capability to deliver any output required.

LED #	Drive Current	Lumen Package	Lens	Distribution	3000K 70CRI				4000K 70CRI				5000K 70CRI							
					Lumen	Bug Rating			Efficacy (Lm/W)	Lumen	Bug Rating			Efficacy (Lm/W)	Lumen	Bug Rating			Efficacy (Lm/W)	
72	425	700mA Microcore Equivalent	None	1	10329	1	0	1	107.6	10695	1	0	1	111.4	11072	1	0	1	115.3	
				2	9941	2	0	2	103.6	10294	2	0	2	107.2	10656	2	0	2	111.0	
				3	10030	2	0	2	104.5	10386	2	0	2	108.2	10751	2	0	2	112.0	
				4W	10139	2	0	2	105.6	10498	2	0	3	109.4	10868	2	0	3	113.2	
				1-HS	5593	0	0	1	58.3	5792	0	0	1	60.3	5995	0	0	1	62.5	
				2-HS	4620	0	0	1	48.1	4784	0	0	1	49.8	4952	0	0	1	51.6	
				3-HS	4690	0	0	1	48.9	4857	0	0	1	50.6	5028	0	0	1	52.4	
				4W-HS	4089	0	0	1	42.6	4234	1	0	1	44.1	4383	1	0	1	45.7	
				5Q	10762	3	0	1	112.1	11143	3	0	1	116.1	11535	3	0	1	120.2	
				5W	10148	4	0	2	105.7	10508	4	0	2	109.5	10877	4	0	2	113.3	
				Clear	1-CL	7746	1	0	1	80.7	8021	1	0	1	83.6	8303	1	0	1	86.5
					2-CL	7456	1	0	2	77.7	7720	1	0	2	80.4	7992	1	0	2	83.2
					3-CL	7522	1	0	2	78.4	7789	1	0	2	81.1	8063	1	0	2	84.0
					4W-CL	7604	1	0	2	79.2	7873	1	0	2	82.0	8150	1	0	2	84.9
	1-CL-HS	4195	0		0	1	43.7	4343	0	0	1	45.2	4496	0	0	1	46.8			
	2-CL-HS	3465	0		0	1	36.1	3588	0	0	1	37.4	3714	0	0	1	38.7			
	3-CL-HS	3518	0		0	1	36.6	3642	0	0	1	37.9	3771	0	0	1	39.3			
	4W-CL-HS	3067	0		0	1	31.9	3175	0	0	1	33.1	3287	0	0	1	34.2			
	5Q-CL	8071	3		0	1	84.1	8357	3	0	1	87.1	8651	3	0	1	90.1			
	5W-CL	7610	3		0	2	79.3	7880	3	0	2	82.1	8158	3	0	2	85.0			
	Diffused	3-DL	6199	2	0	1	64.6	6419	2	0	2	66.9	6645	2	0	2	69.2			
		5W-DL	6272	2	0	1	65.3	6494	2	0	1	67.7	6723	2	0	1	70.0			
	500	13000		None	1	11907	1	0	1	104.2	12330	2	0	1	107.9	12764	2	0	1	111.7
					2	11461	2	0	2	100.3	11867	2	0	2	103.8	12285	2	0	2	107.5
					3	11563	2	0	2	101.2	11973	2	0	2	104.7	12394	2	0	2	108.4
					4W	11688	2	0	3	102.2	12103	2	0	3	105.9	12528	2	0	3	109.6
					1-HS	6448	0	0	1	56.4	6677	0	0	1	58.4	6912	1	0	1	60.5
					2-HS	5326	0	0	1	46.6	5515	0	0	1	48.2	5709	0	0	1	49.9
3-HS					5407	1	0	1	47.3	5599	1	0	1	49.0	5796	1	0	1	50.7	
4W-HS					4714	1	0	1	41.2	4881	1	0	1	42.7	5053	1	0	1	44.2	
5Q					12406	3	0	2	108.5	12846	3	0	2	112.4	13298	3	0	2	116.3	
5W					11698	4	0	2	102.3	12113	4	0	2	106.0	12540	4	0	2	109.7	
Clear					1-CL	8930	1	0	1	78.1	9247	1	0	1	80.9	9572	1	0	1	83.7
					2-CL	8595	2	0	2	75.2	8900	2	0	2	77.9	9213	2	0	2	80.6
					3-CL	8672	1	0	2	75.9	8979	2	0	2	78.6	9295	2	0	2	81.3
					4W-CL	8766	1	0	2	76.7	9077	2	0	2	79.4	9396	2	0	2	82.2
		1-CL-HS	4836	0	0	1	42.3	5007	0	0	1	43.8	5183	0	0	1	45.3			
		2-CL-HS	3995	0	0	1	34.9	4136	0	0	1	36.2	4282	0	0	1	37.5			
		3-CL-HS	4055	0	0	1	35.5	4199	0	0	1	36.7	4347	0	0	1	38.0			
		4W-CL-HS	3535	0	0	1	30.9	3661	0	0	1	32.0	3789	0	0	1	33.2			
		5Q-CL	9304	3	0	1	81.4	9634	3	0	1	84.3	9973	3	0	1	87.2			
		5W-CL	8773	3	0	2	76.8	9085	3	0	2	79.5	9404	3	0	2	82.3			
Diffused		3-DL	7147	2	0	2	62.5	7400	2	0	2	64.7	7660	2	0	2	67.0			
		5W-DL	7231	2	0	1	63.3	7487	2	0	1	65.5	7750	3	0	1	67.8			

DELIVERED LUMENS CONTINUED

The table below shows the delivered lumens for the various lumen outputs and beam distributions. Use this chart in connection with the lumen factor (LF) capability to deliver any output required.

LED #	Drive Current	Lumen Package	Lens	Distribution	3000K 70CRI				4000K 70CRI				5000K 70CRI							
					Lumen	Bug Rating			Efficacy (Lm/W)	Lumen	Bug Rating			Efficacy (Lm/W)	Lumen	Bug Rating			Efficacy (Lm/W)	
72	700	17000	None	1	15594	2	0	1	97.6	16147	2	0	2	101.0	16715	2	0	2	104.6	
				2	15009	2	0	2	93.9	15541	2	0	2	97.3	16088	2	0	2	100.7	
				3	15142	2	0	3	94.8	15679	2	0	3	98.1	16231	2	0	3	101.6	
				4W	15306	2	0	3	95.8	15849	2	0	4	99.2	16407	2	0	4	102.7	
				1-HS	8444	1	0	1	52.8	8744	1	0	1	54.7	9051	1	0	1	56.6	
				2-HS	6975	1	0	1	43.7	7223	1	0	1	45.2	7477	1	0	1	46.8	
				3-HS	7081	1	0	2	44.3	7332	1	0	2	45.9	7590	1	0	2	47.5	
				4W-HS	6173	1	0	1	38.6	6392	1	0	1	40.0	6617	1	0	1	41.4	
				5Q	16247	4	0	2	101.7	16823	4	0	2	105.3	17415	4	0	2	109.0	
				5W	15320	4	0	2	95.9	15863	4	0	2	99.3	16422	4	0	2	102.8	
				Clear	1-CL	11695	1	0	1	73.2	12110	2	0	1	75.8	12536	2	0	1	78.5
					2-CL	11256	2	0	2	70.4	11655	2	0	2	72.9	12066	2	0	2	75.5
					3-CL	11356	2	0	2	71.1	11759	2	0	2	73.6	12173	2	0	2	76.2
					4W-CL	11479	2	0	3	71.8	11886	2	0	3	74.4	12305	2	0	3	77.0
					1-CL-HS	6333	0	0	1	39.6	6557	0	0	1	41.0	6788	1	0	1	42.5
			2-CL-HS		5231	0	0	1	32.7	5417	0	0	1	33.9	5607	0	0	1	35.1	
			3-CL-HS		5311	1	0	1	33.2	5499	1	0	1	34.4	5693	1	0	1	35.6	
			4W-CL-HS		4630	1	0	1	29.0	4794	1	0	1	30.0	4963	1	0	1	31.1	
			5Q-CL		12185	3	0	2	76.3	12617	3	0	2	79.0	13061	3	0	2	81.7	
			5W-CL		11490	4	0	2	71.9	11897	4	0	2	74.5	12316	4	0	2	77.1	
			Diffused	3-DL	9359	2	0	2	58.6	9691	2	0	2	60.6	10032	2	0	2	62.8	
				5W-DL	9469	3	0	2	59.3	9805	3	0	2	61.4	10150	3	0	2	63.5	

PHOTOMETRY

PROL2-72L-700-4K7-1

LUMINAIRE DATA

Description	4000 Kelvin, 70CRI
Delivered Lumens	16,147
Watts	159.8
Efficacy	101.0
IES Type	I
BUG Rating	B2-U0-G2
Mounting Height	30 ft
Grid Scale	30 ft

ZONAL LUMEN SUMMARY

Zone	Lumens	% Luminaire
Downward Street Side	13906	86%
Downward House Side	2241	14%
Downward Total	16147	100%
Upward Street Side	0	0%
Upward House Side	0	0%
Upward Total	0	0%
Total Flux	16147	100%

ISOFOOT CANDLE PLOT

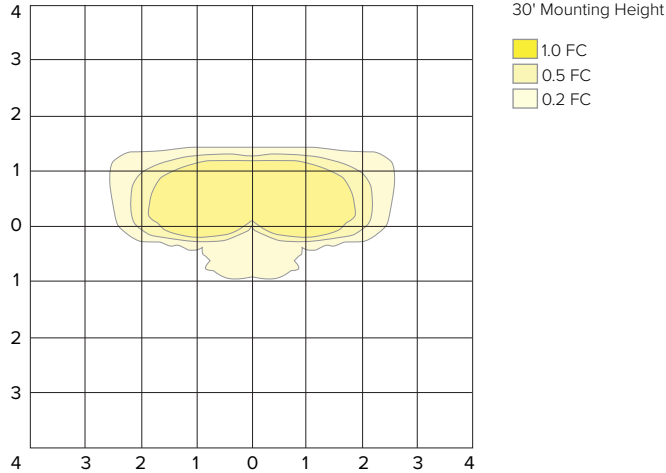

PROL2-72L-700-4K7-2

LUMINAIRE DATA

Description	4000 Kelvin, 70CRI
Delivered Lumens	15,541
Watts	159.8
Efficacy	97.3
IES Type	II
BUG Rating	B2-U0-G2
Mounting Height	30 ft
Grid Scale	30 ft

ZONAL LUMEN SUMMARY

Zone	Lumens	% Luminaire
Downward Street Side	12779	82%
Downward House Side	2762	18%
Downward Total	15541	100%
Upward Street Side	0	0%
Upward House Side	0	0%
Upward Total	0	0%
Total Flux	15541	100%

ISOFOOT CANDLE PLOT

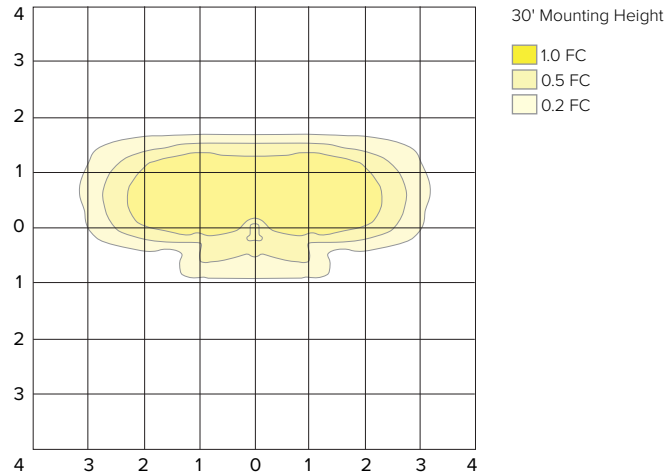

PROL2-72L-700-4K7-3

LUMINAIRE DATA

Description	4000 Kelvin, 70CRI
Delivered Lumens	15,679
Watts	159.8
Efficacy	98.1
IES Type	III
BUG Rating	B2-U0-G3
Mounting Height	30 ft
Grid Scale	30 ft

ZONAL LUMEN SUMMARY

Zone	Lumens	% Luminaire
Downward Street Side	13203	84%
Downward House Side	2476	16%
Downward Total	15679	100%
Upward Street Side	0	0%
Upward House Side	0	0%
Upward Total	0	0%
Total Flux	15679	100%

ISOFOOT CANDLE PLOT

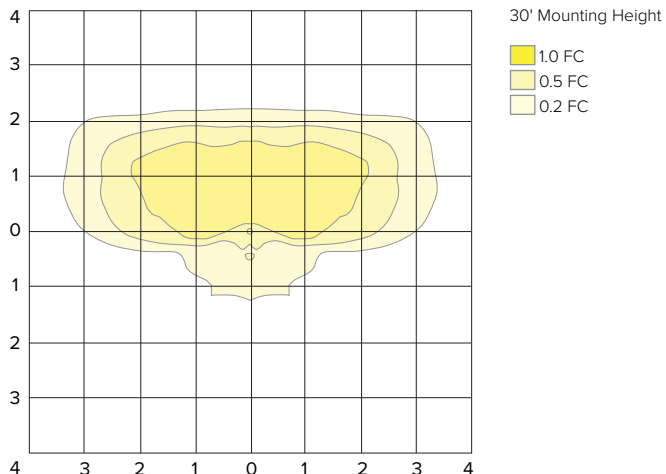

PHOTOMETRY

PROL2-72L-700-4K7-4W

LUMINAIRE DATA

Description	4000 Kelvin, 70CRI
Delivered Lumens	17,103
Watts	159.8
Efficacy	99.2
IES Type	IV Wide
BUG Rating	B2-U0-G4
Mounting Height	30 ft
Grid Scale	30 ft

ZONAL LUMEN SUMMARY

Zone	Lumens	% Luminaire
Downward Street Side	13774	87%
Downward House Side	2076	13%
Downward Total	15850	100%
Upward Street Side	0	0%
Upward House Side	0	0%
Upward Total	0	0%
Total Flux	15850	100%

ISOFOOT CANDLE PLOT

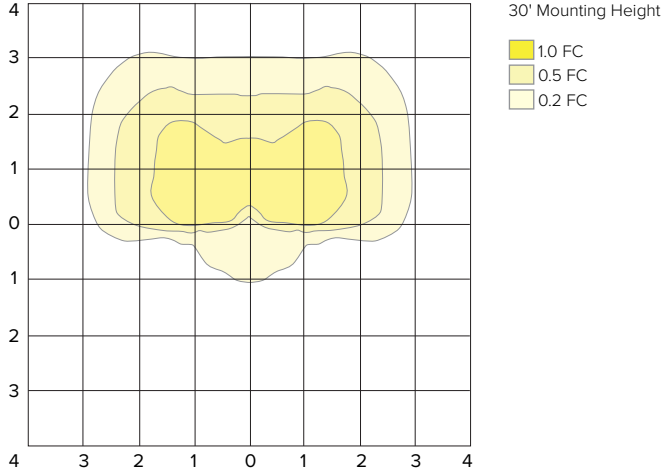

PROL2-72L-700-4K7-5Q

LUMINAIRE DATA

Description	4000 Kelvin, 70CRI
Delivered Lumens	16,824
Watts	159.8
Efficacy	105.3
IES Type	VS
BUG Rating	B4-U0-G2
Mounting Height	30 ft
Grid Scale	30 ft

ZONAL LUMEN SUMMARY

Zone	Lumens	% Luminaire
Downward Street Side	8412	50%
Downward House Side	8412	50%
Downward Total	16824	100%
Upward Street Side	0	0%
Upward House Side	0	0%
Upward Total	0	0%
Total Flux	16824	100%

ISOFOOT CANDLE PLOT

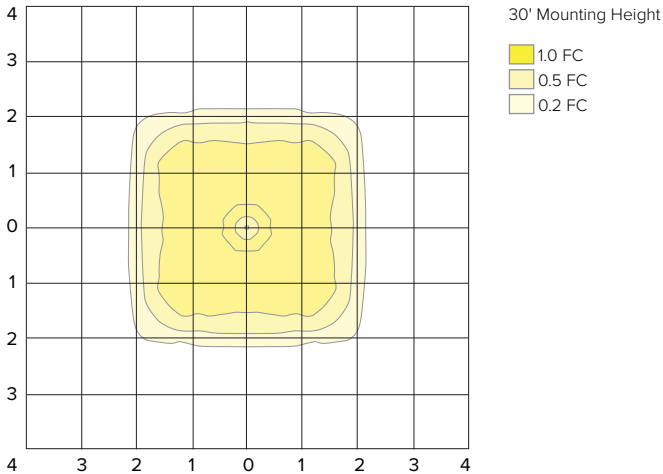

PROL2-72L-700-4K7-5W

LUMINAIRE DATA

Description	4000 Kelvin, 70CRI
Delivered Lumens	15,863
Watts	159.8
Efficacy	99.3
IES Type	VS
BUG Rating	B4-U0-G2
Mounting Height	30 ft
Grid Scale	30 ft

ZONAL LUMEN SUMMARY

Zone	Lumens	% Luminaire
Downward Street Side	7932	50%
Downward House Side	7932	50%
Downward Total	15863	100%
Upward Street Side	0	0%
Upward House Side	0	0%
Upward Total	0	0%
Total Flux	15863	100%

ISOFOOT CANDLE PLOT

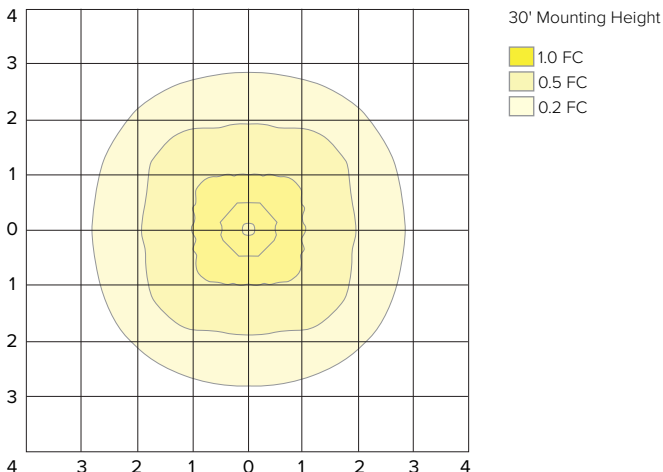

TM-30 DATA

COLOR VECTOR GRAPHIC

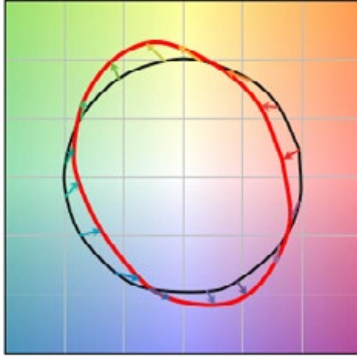

— Reference Illuminant — Test Source

TEST SOURCE

MBM TEST RESULTS	
CCT (K)	3947
CIE Ra	72
Duv	0.0004
x	0.3831
y	0.3793
Rf	68
Rg	99

SPECTRAL POWER DISTRIBUTION COMPARISON

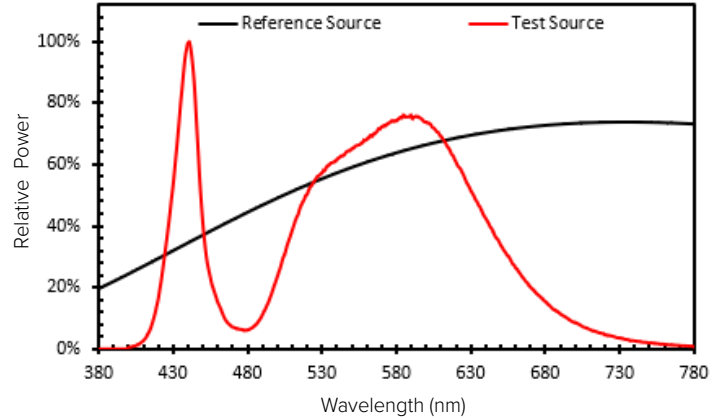

ELECTRICAL DATA

Light Engine	Electrical								Dimming						
	System Current	System Watts	Line Voltage		Amps AC				Min. Power Factor	Max THD (%)	Dimming Range	Source current out of 0-10V		Absolute voltage range on 0-10V (+)	
			VAC	HZ	120	208	240	277				Min	Max	Min	Max
72	270 mA	60.51	120-277	50/60	0.50	0.29	0.25	0.22	>0.9	20	10% to 100%	0mA	1mA	0V	10V
	335 mA	75.7			0.63	0.36	0.32	0.27							
	425 mA	96			0.80	0.46	0.40	0.35							
	500 mA	114.3			0.95	0.55	0.48	0.41							
	700 mA	159.8			1.33	0.77	0.67	0.58							

TM-21 LIFETIME CALCULATION - PROJECTED LUMEN MAINTENANCE (25°C / 77°F)						
HOURS	0	25,000	36,000	50,000	100,000	REPORTED L70
Projected Lumen Maintenance	100%	98.1%	96.9%	95.6%	90.7%	> 60,000

AMBER MULTIPLIER	
CCT	MULTIPLIER
5000K	1
AM	0.1727

2700K MULTIPLIER	
CCT	MULTIPLIER
5000K	1
2700K	0.897

LENS OPTION MULTIPLIER	
CLEAR LENS	DIFFUSED LENS
0.7499	0.618