

# Banner Arms

ARMS

## Banner Arm Mounting Styles

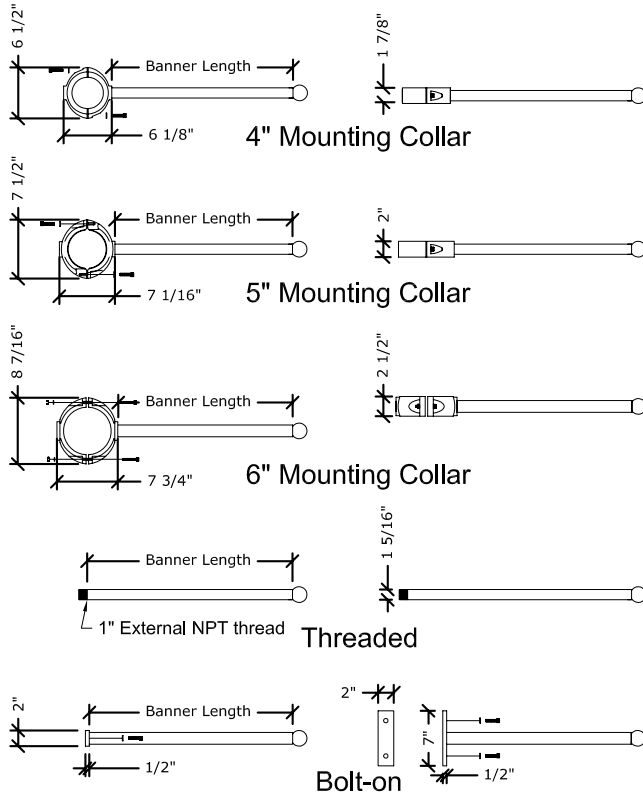

## Specifications

### Construction:

All cast aluminum parts shall low copper alloy A356. All extruded aluminum parts shall be alloy 6061-T6, 6063-T5 or equal.

### Fasteners:

All fasteners shall be stainless steel. When tamper resistant fasteners are required, spanner HD (snake eye) style shall be provided (special tool required, available at additional cost), consult factory for availability.

### Finish:

Finish shall be Beacote III polyester powdercoat electrostatically applied and thermocured. Poles shall be subjected to chemical pre-treatment prior to painting by immersion process.

## Options

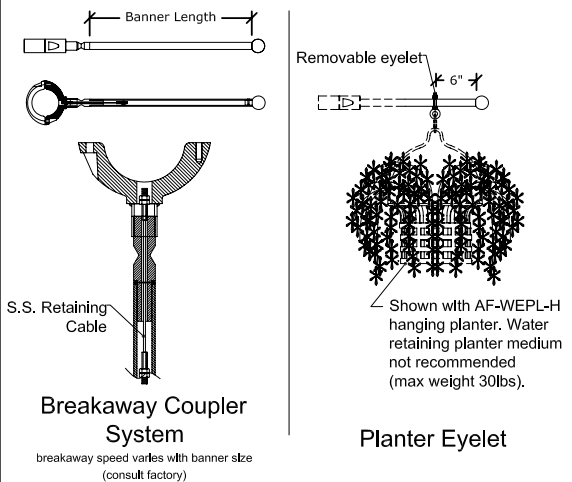

### Ordering Example:

AA-0024 / 4"MTC / BA / BKT

## AA-00

Length	Mounting	Options	Finish
<input type="checkbox"/> 18 18"	<input type="checkbox"/> 4"MTC mounting collar for 4" shaft	<input type="checkbox"/> BA breakaway coupler system*	<input type="checkbox"/> BB black
<input type="checkbox"/> 20 20"	<input type="checkbox"/> 5"MTC mounting collar for 5" shaft	<input type="checkbox"/> PA removable planter eyelet*	<input type="checkbox"/> BZ bronze
<input type="checkbox"/> 22 22"	<input type="checkbox"/> 6"MTC mounting collar for 6" shaft	<input type="checkbox"/> 2X two banner arms at 180°	<input type="checkbox"/> BG green
<input type="checkbox"/> 24 24"	<input type="checkbox"/> BO bolted connection		<input type="checkbox"/> BW white
<input type="checkbox"/> 30 30"	<input type="checkbox"/> TO threaded connection		<input type="checkbox"/> BY gray
			<input type="checkbox"/> RAL RAL-
			<input type="checkbox"/> OTHER

Consult factory for premium and verde finishes. Custom colors available.

### Notes:

\* Consult factory