

HA11

SIDE POLE SWEEPED CAST ARM

Type:
Job:
Ordering Example:

1A / AE17H3 / 150PMH277 / LG-P / HA11S-TM1 / HAF2

Mtg. Fixture Elec Module Finish Options

Ordering Information

Always refer to the specific luminaire catalog, and the ordering information page within that catalog. Place the optional Heritage Arm catalog number as an "Option" following the Fixture catalog numbers.

Approvals:

Specifications

**HA11L
Large Arm**

for Kim RA25, AE21, BE21, and LET26 fixtures only.

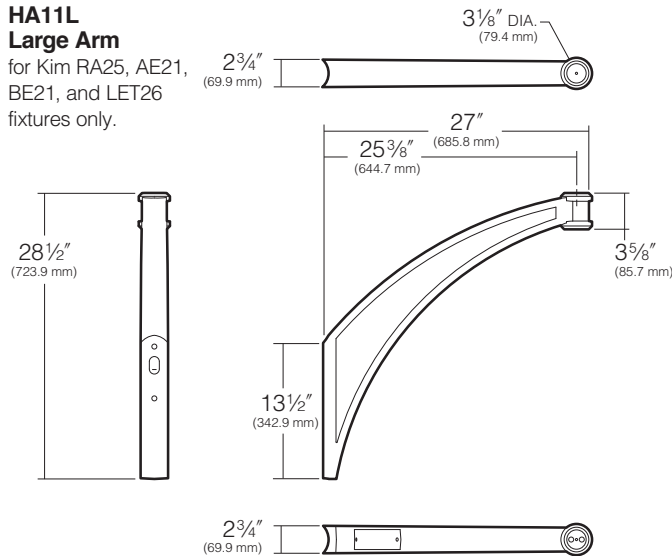

**HA11S
Small Arm**

for Kim RA17, AE17, BE17, NS, SRS, and LET19 fixtures.

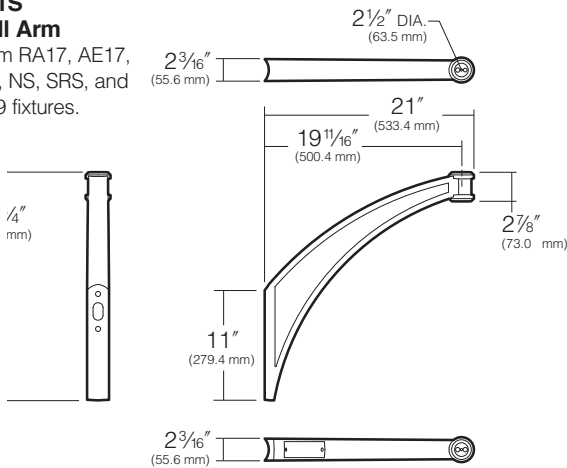

Arm: One-piece, cast aluminum side-mounted arm and cover. Fixture mounting arm is open for access to wiring connections and stainless steel mounting bolts, and enclosed by a flush mounted cast aluminum cover secured with stainless steel screws. Optional cast aluminum finial may be selected to close off fixture mounting hub (flat cap standard). Attachment to pole is by 3/8" stainless steel bolts. Stainless steel bolts thread into a pole backing plate located inside the pole. Pole backing plate is heavy gauge zinc plated steel, and includes a wire strain relief and grounding connection. For round poles, arm is circular cut for the specific pole diameter. Arm-to-luminaire attachment is by concealed stainless steel rods, projecting into the fixture where nuts and washers secure the mounting. Small arm utilizes 3/8" studs and large arm utilizes 1/2" studs.

Finish: Premium Super TGIC thermoset polyester powder coating, 2.5 mil nominal thickness, applied over a titanated zirconium conversion coating. Arm color is always provided to match the selected pole and luminaire color.

Optional Arm Finial: (See page 3)

Optional Wall Mount: (See page 3)

Optional Tenon Mount: (See page 3)

NOTES:

- 1) Refer to page **75** of Arms and Poles Selection Guide for wind map and application information.
- 2) Refer to pages **78** and **79** of Arms and Poles Selection Guide for luminaire Optical Centerline Matrix.
- 3) A regularly scheduled maintenance program must be established to insure paint coating is intact, corrosion or structural damage has not occurred, and all mounting rods, nuts and bolts are tight. Failure to do so could lead to damage or serious personal injury.





HA11

SIDE POLE SWEEP CAST ARM

Type:

Job:

Standard Features

ERA® Arm	Arm/Fixture	Mounting Configuration					
HA11		Plan View:					
		Cat. No.:	1A	2B	3Y	4C	1W
		Large	EPA:				
		HA11L - RA25	2.3	4.8	5.8	6.3	n/a
		HA11L - AE21/BE21	2.2	4.4	5.5	5.9	n/a
		HA11L - LET26	2.3	4.6	5.8	6.6	n/a
		Small					
		HA11S - RA17	1.5	3.0	3.8	4.1	n/a
		HA11S - AE17/BE17	1.4	2.8	3.5	3.8	n/a
		HA11S - NS	1.8	3.6	4.7	5.2	n/a
	HA11S - SRS	2.3	4.6	5.6	6.3	n/a	
	HA11S - LET19	1.7	3.4	4.4	4.9	n/a	

HA11

SIDE POLE SWEPT CAST ARM

Type:

Job:

Optional Features

Wall Mounting

Cat. No. **1W**

Select from Mounting on page **2**.

A cast mounting plate of aluminum is mounted to the wall with bolts (by others). Fixture and arm are mounted to a cast aluminum cover plate before attaching to the wall mounting plate. The fixture-arm-cover plate assembly is hooked to the wall mounting plate, and secured with stainless steel screws provided. After mounting to the wall, field splices are made at the opening in the cover plate, then covered by a cast aluminum plate that blends with the cover plate design. Complete fixture-arm-cover plate assembly can therefore be mounted before field splices are made. Cover plate is finished to match arm and fixture powder coat color.

CAUTION: Structural integrity of mounting plate attachment to wall is by others.

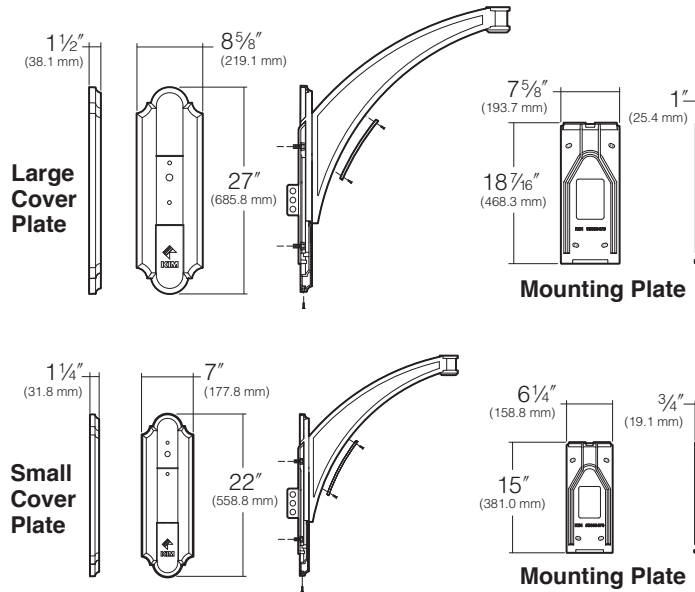

Arm Finials

Traditional style finial available to close off mounting hub opposite the fixture. Finial is cast aluminum finished to match arm and fixture powder coat color.

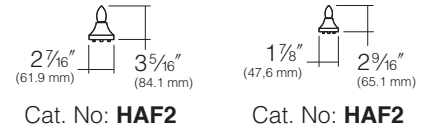

Tenon Mount
(Poles by others)

NOTE: All small arm assemblies require a steel 2" pipe tenon (2 3/8" O.D.) x 4" long.

All large arm assemblies require a steel 2 1/2" pipe tenon (2 7/8" O.D.) x 4" long.

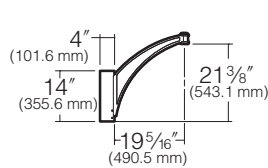

Side Pole Swept Cast Arm - Small

Cat. No.	Mounting
HA11S-TM1	1A
HA11S-TM2	2B
HA11S-TM3	3Y
HA11S-TM4	4C

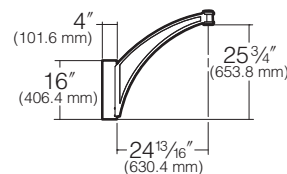

Side Pole Swept Cast Arm - Large

Cat. No.	Mounting
HA11L-TM1	1A
HA11L-TM2	2B
HA11L-TM3	3Y
HA11L-TM4	4C