

# VRBC Round Bollard

UNLIGHTED CONCRETE

**Type:**  
**Job:**  
**Catalog number:**

**Approvals:**

**VRBC /**

Fixture      Concrete Finish

## Specifications

**VRBC - Unlighted Concrete Bollard**  
 Maximum weight: 150 lb

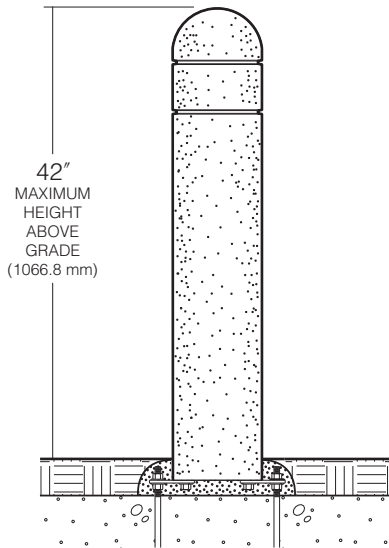

**BASE PLAN  
 VRBC**

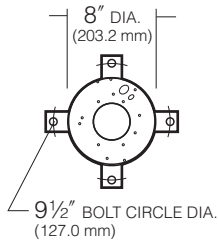

**NOTE:** No fixture, electrical elements, or conduit openings. Flat top not available.

**Material:** Cement shall conform to current specifications for "Portland Cement." ASTM C150, Type I or II. Aggregates shall meet current requirements of "Specifications for Concrete Aggregates," ASTM C33. Water shall be clean and free from deleterious amounts of silt, oil, acids, alkalies or organic materials. Wire for reinforcement shall conform to ASTM A185. Steel for lugs and plates shall conform to ASTM A36, or A283 grade D.

**Surface:** Medium sand-blasted with anti-graffiti sealer. Available colors are Charcoal, Brown, Natural Gray or White, integral in concrete mix.

**Cure and Strength:** Allows for completion of the hydration process, and result in a 28 day compressive strength of not less than 4,500 psi.

**Manufacture:** Fiberglass molds used to insure uniform parts. Mold parting lines may be slightly visible in finished parts.

**Anchorage:** Four steel mounting tabs for installation on four 1/2" x 10" + 2" zinc electroplated L-hook anchor bolts. Each anchor bolt is supplied with two nuts, two washers, and a rigid pressed board template.

**Shipment:** Palletized with adequate hold-downs to prevent load movement in transit.

### Concrete Finish<sup>1</sup>

- VRBBCD@ Brown
- VRBBCBL Charcoal
- VRBBCLG Natural Gray
- VRBBCWH White

<sup>1</sup>Shaft surface color is integral in concrete mix.