



LAMPAK® SPRTS

Single-Pole Remote Test Switch/Charge Indicator

Catalog Number	
Comments	Type

FEATURES

Application

The SPRTS remote test switch and charge indicator is used with Dual-Lite's UFO-3AW, 4W, 5W, 6W, 7W, CF, LP, and LED Series emergency battery packs to provide test and charge indicator capability to a convenient wall location.

Construction

The SPRTS remote test switch/charge indicator is constructed of a UL/CSA-approved white faceplate sized to fit a single-gang electrical box, a UL/CSA-approved single-pole, normally-closed, momentary test switch and a UL/CSA-approved single red LED charging indicator.

Installation

The SPRTS can be located up to 50ft from the battery pack it is used with. Refer to the individual battery pack's Installation Instructions for appropriate wiring diagrams. The UFO-CF and UFO-LED Series battery packs are individually provided with (1) SPRTS.

Operation

To manually test for proper operation of UFO-3AW, 4W, 5W, 6W, 7W, CF, LP and LED Series battery packs, push and hold the test button. This will simulate a loss of utility power causing the battery pack's automatic transfer circuit to switch to emergency mode and illuminate one or two lamps, depending on the specific battery pack and fixture combination. When the test button is not pressed, and therefore not in emergency mode, the charging indicator LED will illuminate if the battery pack is properly being recharged.

Standard Features Include

- For use with Dual-lite Lampak® UFO-3AW, 4W, 5W, 6W, 7W, CF, LP, and LED Series emergency battery packs
- For remote installation of the test switch and charge-rate indicator on wall in convenient testing area
- Can be mounted up to 50 ft. from unit
- Can be used with emergency battery packs supplied with a single-pole test switch
- Fits single-gang electrical box (not supplied)

Compliances

UL924 (in use with specified battery pack)

Warranty

1 Years Full Warranty



DIMENSIONS

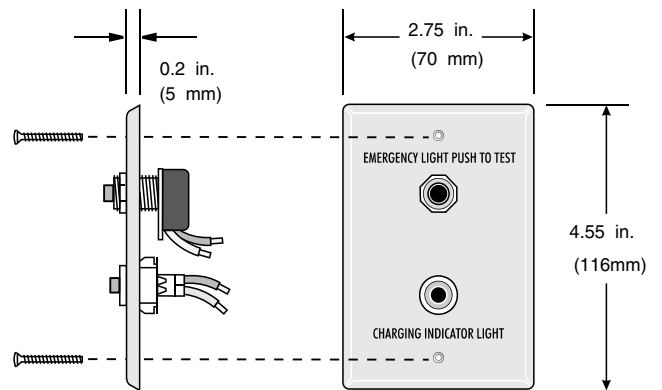

ORDERING GUIDE

SPRTS

