

Bottom View

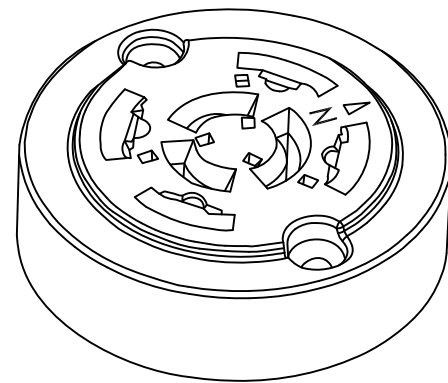
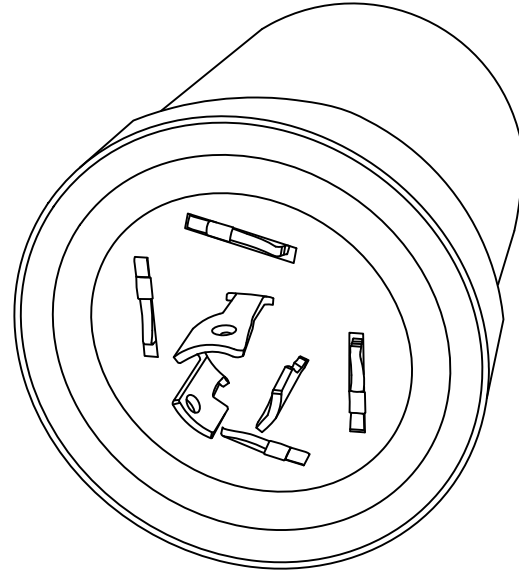

Compliant with:
ANSI C136-41 (7 & 5 pin) twist-lock receptacles.
Receptacle not included.

NOTES:

Power down fixture prior to installation.

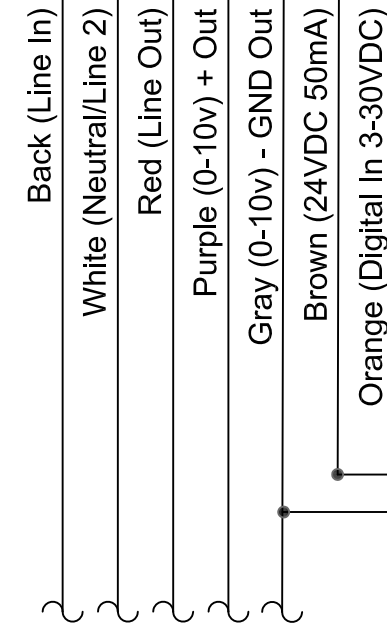
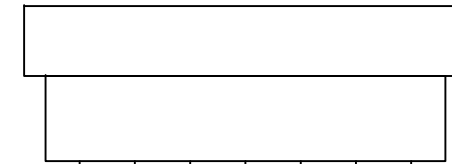
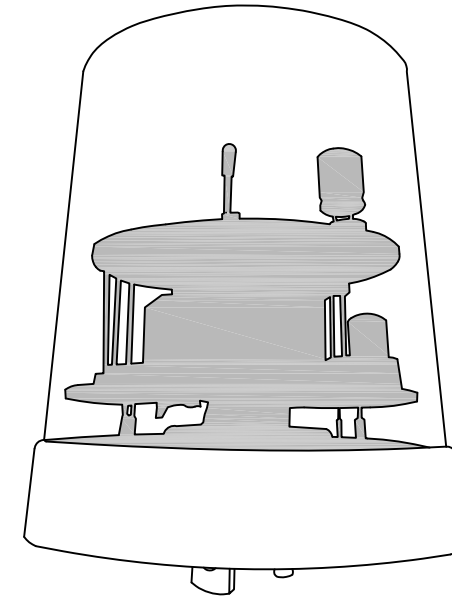

**WASP2
Low Voltage
Occupancy Sensor**

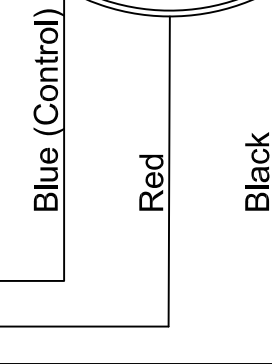
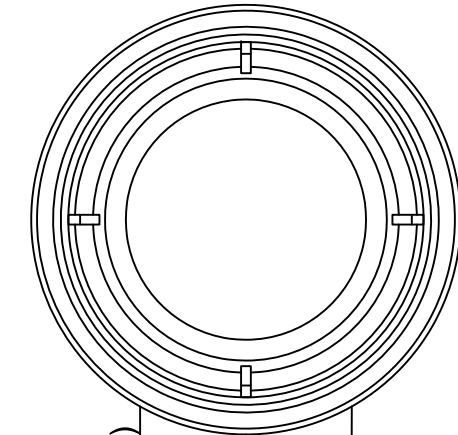

HUBBELL
Control Solutions

WIR-RME

THIS DOCUMENT AND SPECIFICATIONS DESCRIBED WITHIN ARE THE EXCLUSIVE PROPERTY OF HUBBELL CONTROL SOLUTIONS ISSUED IN THE STRICTEST CONFIDENCE, AND SHALL NOT BE REPRODUCED, COPIED OR USED WITHOUT PRIOR WRITTEN PERMISSION.